

GOODWE



User Manual

Hybrid Inverter

ES Series

5.0-11.4kW G2(US)

AC-Coupled Inverter

SBP Series

5.0-11.4kW G2(US)

V1.3-2026-04-09

Trademarks

GOODWE and other GOODWE trademarks are trademarks of GoodWe Technologies Co.,Ltd. All other trademarks or registered trademarks mentioned in this manual are owned by GoodWe Technologies Co.,Ltd.

NOTICE

The information in this user manual is subject to change due to product updates or other reasons. This guide cannot replace the product labels or the safety precautions in the user manual unless otherwise specified. All descriptions here are for guidance only.

CONTENT

- 1 About This Manual..... 1**
 - 1.1 Applicable Model1
 - 1.2 Target Audience1
 - 1.3 Symbol Definition2
- 2 IMPORTANT SAFETY INSTRUCTIONS 3**
 - 2.1 General Safety3
 - 2.2 PV String Safety3
 - 2.3 Inverter Safety4
 - 2.4 Battery5
 - 2.5 Personnel Requirements5
- 3 Product Introduction 6**
 - 3.1 Product Overview6
 - 3.2 Application Scenarios7
 - 3.3 Working Mode18
 - 3.3.1 System working mode18
 - 3.3.2 EV Charger Working Mode21
 - 3.3.3 Inverter operation mode22
 - 3.4 Functionality23
 - 3.5 Appearance25
 - 3.5.1 Parts25
 - 3.5.2 Dimension26
 - 3.5.3 Indicators26
 - 3.5.4 Nameplate27
- 4 Check and Storage28**
 - 4.1 Check Before Receiving28
 - 4.2 Deliverables28
 - 4.3 Storage29
- 5 Installation30**
 - 5.1 Installation Requirements30
 - 5.2 Inverter Installation33
 - 5.2.1 Moving the Inverter33
 - 5.2.2 Installing the Inverter33
- 6 Electrical Connection.....36**
 - 6.1 Safety Precaution36
 - 6.2 Preparations before Installation37
 - 6.2.1 Terminal introduction37
 - 6.2.2 Cable Specification38
 - 6.3 Opening the wiring cover41

6.4	Connecting the DC Input Cable(PV)	41
6.5	Connecting the battery cable	43
6.6	Connecting the AC Cable	44
6.7	Connecting the EV cables	45
6.8	Communication	46
6.8.1	Connecting the Communication Cable (Use pin connectors)	46
6.8.2	Connecting the Communication Cable (for RJ45 crystal terminal connection).....	48
6.8.3	Installing the SIM card (optional).....	49
6.8.4	Installing the antenna.....	49
6.8.5	Installing the Cover	50
7	Equipment Commissioning.....	51
7.1	Check Before Power ON.....	51
7.2	Power On	51
8	System Commissioning	52
8.1	Indicators and Buttons	52
8.2	Setting Inverter Parameters via SolarGo App	53
8.3	Monitoring via SEMS Portal	53
9	Maintenance.....	54
9.1	Power Off the Inverter.....	54
9.2	Removing the Inverter	54
9.3	Disposing of the Inverter	54
9.4	Troubleshooting.....	55
9.5	Routine Maintenance.....	63
10	Technical Parameters.....	64
10.1	ES Inverter Parameters	64
10.2	SBP Inverter Parameters	70
10.3	Technical Parameters for EV Charger	75
11	Appendix.....	76
11.1	Inverter Parameter Precision.....	76

1 About This Manual

This manual describes the product information, installation, electrical connection, commissioning, troubleshooting, and maintenance. Read through this manual before installing and operating the product. All the installers and users have to be familiar with the product features, functions, and safety precautions. This manual is subject to update without notice. For more product details and latest documents, please visit <https://en.goodwe.com>.

1.1 Applicable Model

This manual applies to the listed inverters below:

ES Series: Hybrid Inverter

- GW5000-ES-US20
- GW6000-ES-US20
- GW7600-ES-US20
- GW9600-ES-US20
- GW11K4-ES-US20

SBP Series: AC-Coupled Inverter





- GW5000-SBP-US20
- GW6000-SBP-US20
- GW7600-SBP-US20
- GW9600-SBP-US20
- GW11K4-SBP-US20

1.2 Target Audience

This manual applies to trained and knowledgeable technical professionals only. The technical personnel has to be familiar with the product, local standards, and electric systems.

1.3 Symbol Definition

Different levels of warning messages in this manual are defined as follows:

 DANGER
Indicates a high-level hazard that, if not avoided, will result in death or serious injury.
 WARNING
Indicates a medium-level hazard that, if not avoided, could result in death or serious injury.
 CAUTION
Indicates a low-level hazard that, if not avoided, could result in minor or moderate injury.
 NOTICE
Highlight and supplement the texts. Or some skills and methods to solve product-related problems to save time.

2 IMPORTANT SAFETY INSTRUCTIONS

SAVE THESE INSTRUCTIONS

Please strictly follow these safety instructions in the user manual during the operation.

NOTICE

The inverters are designed and tested strictly complies with related safety rules. Read and follow all the safety instructions and cautions before any operations. Improper operation might cause personal injury or property damage as the inverters are electrical equipment.

2.1 General Safety

Notice

- The information in this user manual is subject to change due to product updates or other reasons. This guide cannot replace the product labels or the safety precautions in the user manual unless otherwise specified. All descriptions in the manual are for guidance only.
- Before installations, read through the user manual to learn about the product and the precautions.
- All installations should be performed by trained and knowledgeable technicians who are familiar with local standards and safety regulations.
- Use insulating tools and wear personal protective equipment when operating the equipment to ensure personal safety. Wear anti-static gloves, cloths, and wrist strips when touching electron devices to protect the inverter from damage.
- Strictly follow the installation, operation, and configuration instructions in this manual. The manufacturer shall not be liable for equipment damage or personal injury if you do not follow the instructions. For more warranty details, please visit: <https://en.goodwe.com/warranty>

2.2 PV String Safety



DANGER

Connect the DC cables of the inverter to the delivered DC terminals. DC terminals not recommended in the manual might cause severe consequences. The manufacturer shall not be liable for the equipment damage if other DC terminals are used.













WARNING

- Ensure the component frames and the bracket system are securely grounded.
- Ensure the DC cables are connected tightly, securely, and correctly.
- Measure the DC cables with a multimeter to avoid reverse polarity connection. Also, the voltage should be under the permissible range.
- Do not connect one PV string to more than one inverter at the same time. Otherwise, it may cause damage to the inverter.

2.3 Inverter Safety

 WARNING	
<ul style="list-style-type: none"> • The voltage and frequency at the connecting point should meet the on-grid requirements. • Additional protective devices like circuit breakers or fuses are recommended on the AC side. Specification of the protective device should be at least 1.25 times the AC rated output current. • Make sure that all the groundings are tightly connected. When there are multiple inverters, make sure that all the grounding points on the enclosures are equipotential bonding. • Electric arcs alarm. The alarm can be cleared automatically if the inverter triggers a fault for less than 5 times within 24 hours. The inverter will shutdown for protection after the 5th electric arc fault. The inverter can operate normally after the fault is solved. • BACK-UP is not recommended if the PV systems does not configured with battery. Otherwise, the risk in system power usage is beyond the equipment manufacturer's warranty scope. • Strictly follow the recommended cable specification and tightening torque requirement during installation or wiring. 	

 DANGER	
<ul style="list-style-type: none"> • Do not use the inverter when any damage being found. Do not use this product if there is any damage to the unit. • All labels and warning marks should be visible after the installation. Do not cover, scrawl, or damage any label on the equipment. • Warning labels on the inverter are as follows: 	

	HIGH VOLTAGE HAZARD High voltage exists during the inverter's running. Disconnect all incoming power and turn off the product before working on it.		Delay discharge. Wait 5 minutes after power off until the components are completely discharged.
	Read through the user manual before any operations.		Potential risks exist. Wear proper PPE before any operations.
	High-temperature hazard. Do not touch the product under operation to avoid being burnt.		Grounding point.
	CSA Marking for the United States of America and Canada		Do not dispose of the inverter as household waste. Discard the product in compliance with local laws and regulations, or send it back to the manufacturer.
	Support Type 1 DC Arc detection on PV side.	-	-

2.4 Battery



WARNING

- The battery used with the inverter shall be approved by the inverter manufacturer. The approved battery list can be obtained through the official website.
- Before installations, read through the corresponding battery's User Manual to learn about the product and the precautions. Strictly follow its requirements.
- If the battery discharged completely, please charge it in strict accordance with the corresponding model's User Manual.
- Factors such as: temperature, humidity, weather conditions, etc. may limit the battery's current and affect its load.
- Contact after-sale service immediately if the battery is not able to be started. Otherwise, the battery might be damaged permanently.
- Use the multimeter to measure the DC cable to avoid reverse polarity connection. Also, the voltage should be under the permissible range.
- Do not connect one battery group to several inverters at the same time. Otherwise, it may cause damage to the inverter.

2.5 Personnel Requirements

NOTICE

- Personnel who install or maintain the equipment must be strictly trained, learn about safety precautions and correct operations.
- Only qualified professionals or trained personnel are allowed to install, operate, maintain, and replace the equipment or parts.

3 Product Introduction

3.1 Product Overview

Intended usage

This is Grid Support Utility Interactive Inverter, owning below functions:

Inverters control and optimize the power in PV systems through an integrated energy management system. The power generated in the PV system can be used, stored in the battery, output to the Utility Grid, etc.

Model

This manual applies to the listed inverters below:

ES Series: Hybrid Inverter

- GW5000-ES-US20
- GW6000-ES-US20
- GW7600-ES-US20
- GW9600-ES-US20
- GW11K4-ES-US20

SBP Series: AC-Coupled Inverter

- GW5000-SBP-US20
- GW6000-SBP-US20
- GW7600-SBP-US20
- GW9600-SBP-US20
- GW11K4-SBP-US20

Model description

GW5000-ES-US20



No.	Referring to	Explanation
1	Brand Code	GW: GOODWE
2	Rated Power	<ul style="list-style-type: none"> • 5000: the rated power is 5KW. • 6000: the rated power is 6kW. • 7.600: the rated power is 7.6kW. • 9600: the rated power is 9.6kW. • 11k4: the rated power is 11.4kW.
3	Equipment Type	<ul style="list-style-type: none"> • ES: Hybrid Inverter • SBP: AC-Coupled Inverter
4	Area Code	US: North America
5	Version Code	20: the version of the inverter is 2.0

Supported Grid Types

The inverter supports 120/240V split phase Grid.

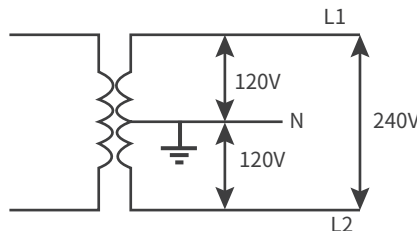

3.2 Application Scenarios



WARNING

- PV system is not suitable to connect equipment that relies on a stable power supply, such as: medical equipment to sustain life. Ensure that no personal injury is occurred when the system is disconnected.
- Avoid using loads with higher starting currents in PV systems, such as: high-power pumps, etc.. Otherwise, it might cause off-grid output failure due to excessive instantaneous power.
- BACK-UP is not recommended if the PV systems does not configured with battery. Otherwise, the risk in system power usage is beyond the equipment manufacturer's warranty scope.
- Factors such as: temperature, humidity, weather, etc. may limit the battery's current and affect its loading capacity.
- For PV systems equipped with rapid shutdown module in PV strings, ensure that it matches the inverter's built-in RSD transmitter. Otherwise, it might fail to use RSD functionality.
- When single overload protection occurs, the inverter can restart automatically; however, the restarting time will be extended if it happens several times. For a faster restarting, try it via APP.
- When the grid is down, the off-grid function of the inverter will be closed automatically if the load capacity exceeds the inverter's rated power; to enable it, turn off the large loads and ensure the load power is less than the rated power of the inverter.
- When the inverter is in off-grid status, it can be used normally for ordinary household loads. However, the following loads must be restricted:
 - Inductive loads: Single Inductive loads power <math>< 0.4</math> times of the inverter's phase rated output power.
 - Capacitive loads: Total power $\leq 0.66 \times$ inverter rated output power.
 - When connecting three-phase loads to the BACK-UP port, only three-phase loads with an N line are supported. Loads without an N line are not supported, as this may cause abnormal operation or damage to the load.
 - The inverter does not support half-wave load. Half-wave load: Some older or non-EMC-compliant appliances (such as hair dryers or small heaters using half-wave rectification) may not function properly.
- Only one ground bond shall exist in the entire system. Multiple ground bonds can result in ground loop currents and pose safety risks.
- If the unit includes a service ground bond or is intended to be connected to other equipment with a service ground bond, the final installation must designate a single, clear point of ground bonding.
- If a service box is installed between the ABD and the utility grid, the single system ground bond shall be made within the service box. This approach helps to centralize the grounding point and ensures that the system complies with the requirements of NEC Article 250.
- Refer to the relevant sections of NEC Article 250 (e.g., 250.24, 250.30) regarding grounding electrode systems and equipment grounding conductors to ensure compliance with local electrical codes.

Strictly follow below requirements to realize anti reverse current:

 **WARNING**

The anti reverse current functionality can be realized when the inverter are used together with ABD or Smart Meter. The application scenarios for the inverter includes: self consumption, partial backup system, whole home backup system and microgrid. All these scenarios own the anti reverse current functionality. Users can choose based on your own demanding. For ABD and Smart Meter operations, refer to ABD&MPD User Manual and GMK120&GMK140&GM330 Quick Installation Guide.

The inverter supports import only and no exchange modes. The inverter is in import only mode when delivered in default (while the corresponding mode in APP is self consumption mode). Set anti reverse current parameters via the APP. The working mode for the system is no exchange mode after the grid requirement is satisfied. For detailed APP operations, refer to SolarGo User Manual.

The password shall be typed when setting the anti reverse current functionality. Contact the after-sale service for setting.

The maximum operating currents in controlled busbars or conductors are limited by the settings of the power control system (PCS) and may be lower than the sum of the currents of the connected controlled power sources. The settings of the PCS controlled currents may be used for calculation of the design currents used in the relevant sections of NEC Article 690 and 705.

Maximum PCS Controlled Current setting: 200 A.

Only qualified personnel shall be permitted to set or change the setting of the maximum operating current of the PCS. The maximum PCS operating current setting shall not exceed the busbar rating or conductor ampacity of any PCS controlled busbar or conductor.

For Supplemental PCS (ABD deployed in the application):

This system is equipped with a PCS. All PCS controlled busbars or conductors shall be protected with suitably rated overcurrent devices appropriately sized for the busbar rating or conductor ampacity.

For Branch Circuit PCS (ABD not deployed in the application):

This system is equipped with a PCS which is suitably rated to provide branch circuit overcurrent protection. The controlled current setting shall not exceed the rating of any controlled busbars or conductor ampacity.

Configuration of power control settings system or changes to settings shall be made by qualified personnel only. Incorrect configuration or setting of the power control settings may result in unsafe conditions.

Stick below tags on the body part of the product(s) in the system with anti-reverse current functionality by yourselves:

PCS Controlled Current Tag

Smart Meter or CT Description Tag

PCS Controlled Current Setting: ____ A
 The maximum operating current of this system may be controlled electronically.
 Refer to user manual for more information

This sensor is part of a Power Control System. Do not remove. Replace only with same type and rating.

Self Consumption System (hybrid scenarios)

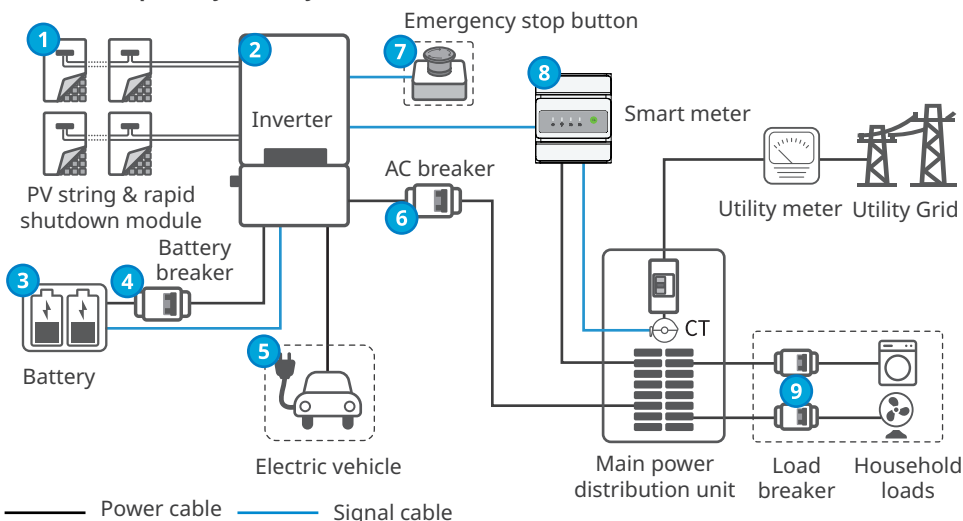

No.	Parts	Description
1	PV string & rapid shutdown module	<ul style="list-style-type: none"> PV String: only for ES series. Rapid shutdown module: only for ES series. Configure the RSD module externally to realize RSD functionality. You can purchase the RSD module from the inverter manufacturer or select RSD-D-XX or Tigo TS4 series from AP Systems. Detailed RSD information supported by the inverter can be obtained from the packing box.
2	Inverter	Support ES and SBP series inverters.
3	Battery	Select the battery model according to the inverter model and the approved battery list.
4	Battery breaker	Recommended specification: nominal current \geq 60A and nominal voltage \geq 500V.
5	Electric vehicle	The inverter supports connecting with EV Charger. Configure it according to users' demanding. The Charger purchased from the inverter manufacturer shall meet J1772 (Type1) standard.
6	AC breaker	2P AC breakers meet the following requirements are recommended: <ul style="list-style-type: none"> GW5000-ES-US20, GW5000-SBP-US20: 30A (50A, EV charger optional) GW6000-ES-US20, GW6000-SBP-US20: 35A (50A, EV charger optional) GW7600-ES-US20, GW7600-SBP-US20: 40A (50A, EV charger optional) GW9600-ES-US20, GW9600-SBP-US20: 50A (50A, EV charger optional) GW11K4-ES-US20, GW11K4-SBP-US20: 60A (60A, EV charger optional)
7	Emergency stop button	The inverter supports connecting with emergency stop button. Configure it according to users' demanding. Recommend to use normally closed contact (NC) emergency stop button certified by UL.
8	Smart meter	The smart meter can be purchased from the manufacturer. Recommended model: GMK120.
9	Load Breaker	Depend on the actual using load.

Self Consumption System(AC-Coupled Scenarios)

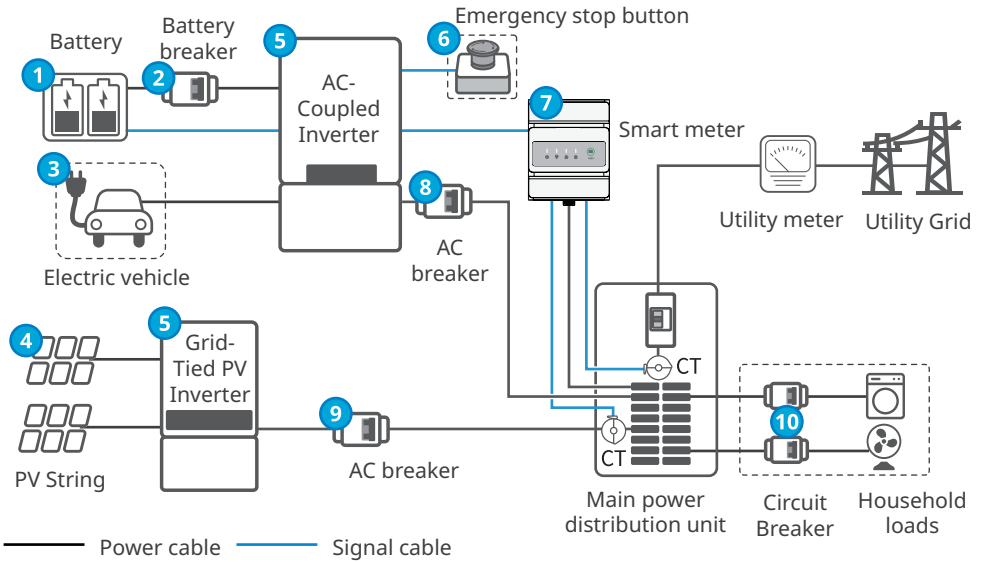

No.	Parts	Description
1	Battery	Select the battery model according to the inverter model and the approved battery list.
2	Battery breaker	Recommended specifications: nominal current $\geq 60A$, nominal voltage $\geq 500V$.
3	Electric vehicle	The inverter supports connecting with EV Charger. Configure it according to users' demanding. The Charger shall meet J1772 (Type1) standard, which can be purchased from the inverter manufacturer.
4	PV String	PV string is composed of series connected PV panels.
5	Inverter	<ul style="list-style-type: none"> For AC-Coupled Inverter: SBP Series For Grid-Tied Inverter: supporting the third Party's PV inverter.
6	Emergency stop button	The inverter supports connecting with emergency stop button. Configure it according to users' demanding. Recommend to use normally closed contact (NC) emergency stop button certified by UL.
7	Smart meter	The smart meter can be purchased from the manufacturer. Recommended model: GMK140.
8	AC breaker	2P AC breakers meet the following requirements are recommended: <ul style="list-style-type: none"> GW5000-ES-US20, GW5000-SBP-US20: 30A (50A, EV charger optional) GW6000-ES-US20, GW6000-SBP-US20: 35A (50A, EV charger optional) GW7600-ES-US20, GW7600-SBP-US20: 40A (50A, EV charger optional) GW9600-ES-US20, GW9600-SBP-US20: 50A (50A, EV charger optional) GW11K4-ES-US20, GW11K4-SBP-US20: 60A (60A, EV charger optional)
9	AC breaker	AC output switch specifications of The PV grid-connected inverter depend on the PV inverters' AC output rated current.
10	Load Breaker	Depend on the actual using load.

Whole Home Backup System

Configure the ABD box (Automatic Backup Device) in the system for a full load solution. Disconnect the grid and the main distribution cabinet when the grid is power off. And the inverter switches to off-grid operation, supplying power to the load continually.

ABD box type I

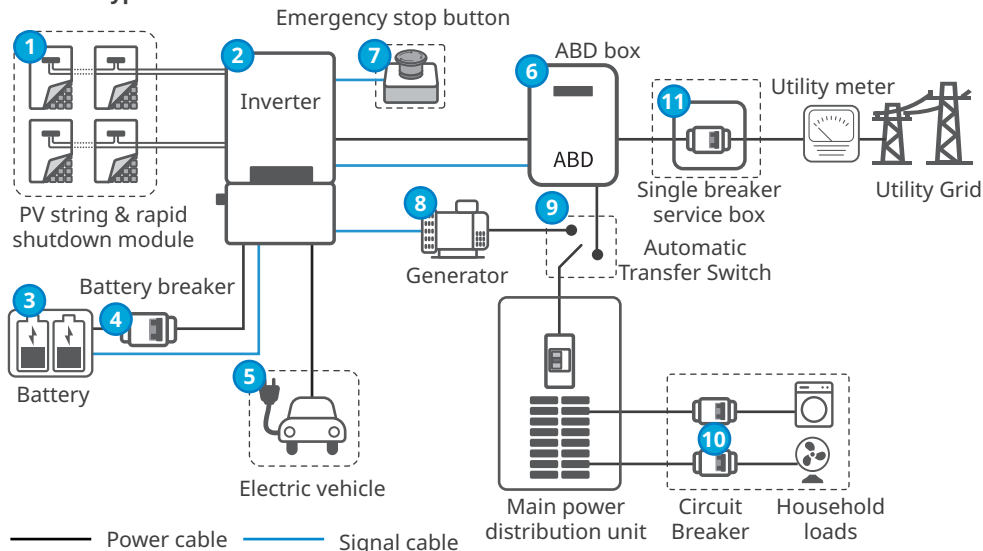

ABD box type II

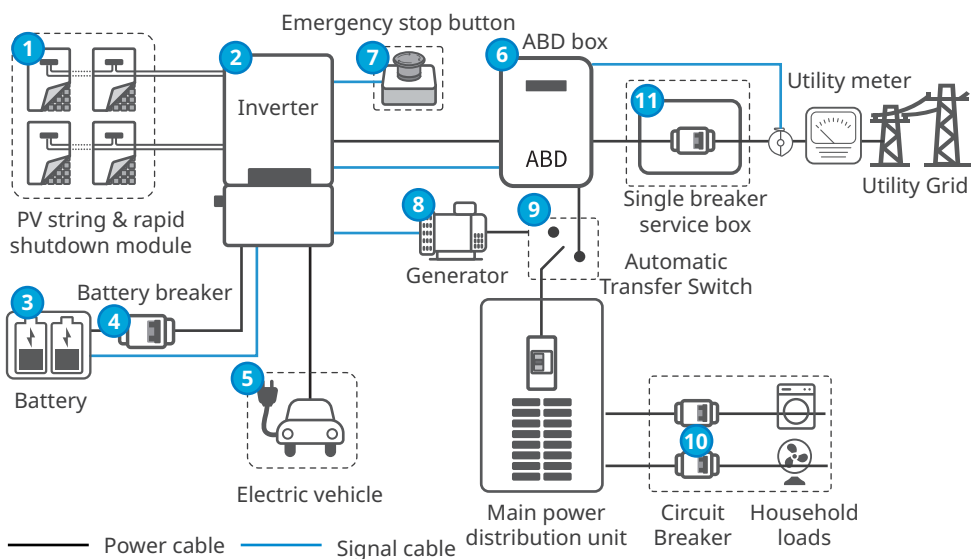

No.	Parts	Description
1	PV string & rapid shutdown module	<ul style="list-style-type: none"> • PV String: only for ES series. • Rapid shutdown module: only for ES series. Configure the RSD module externally to realize RSD functionality. You can purchase the RSD module from the inverter manufacturer or select RSD-D-XX or Tigo TS4 series from AP Systems. Detailed RSD information supported by the inverter can be obtained from the packing box.
2	Inverter	Support ES and SBP series inverters.
3	Battery	Select the battery model according to the inverter model and the approved battery list.
4	Battery breaker	Recommended specifications: nominal current $\geq 60A$, nominal voltage $\geq 500V$.
5	Electric vehicle	The inverter supports connecting with EV Charger. Configure it according to users' demanding. The Charger purchased from the inverter manufacturer shall meet J1772 (Type1) standard.
6	ABD box	<p>The ABD box can be purchased from the manufacturer. Recommended model:</p> <ul style="list-style-type: none"> • ABD100-40-US10, ABD200-40-US10: use with inverter of 5.0-7.6kW rated power. • ABD100-63-US10, ABD200-63-US10: use with inverter of 9.6-11.4kW rated power.
7	Emergency stop button	The inverter supports to connect with emergency stop button. Configure it according to users' demanding. Recommend to use normally closed contact (NC) emergency stop button certified by UL.
8	Generator	The inverter supports to connect with generators. Configure it according to users' demanding. An fully automatic split-phase generator is recommended.
9	Automatic Transfer Switch	When the system is configured with a generator, it shall also use an automatic transfer switch. When the transfer switch detects that the generator has voltage, it will be switched to the generator automatically for load supplying.
10	Load Breaker	Depend on the actual using load.
11	Single breaker service box	Optional in compliance with local laws and regulations. Requirements are recommended: 200A rated, UL listed and Service rated.

Partial Backup System

The system is equipped with an ABD box (automatic backup device) to provide a backup power solution for specific loads. When the local grid fails, the loads in the main distribution board lose power; the inverter switches to off-grid operation mode and continues to supply power to the loads in the sub-distribution board.

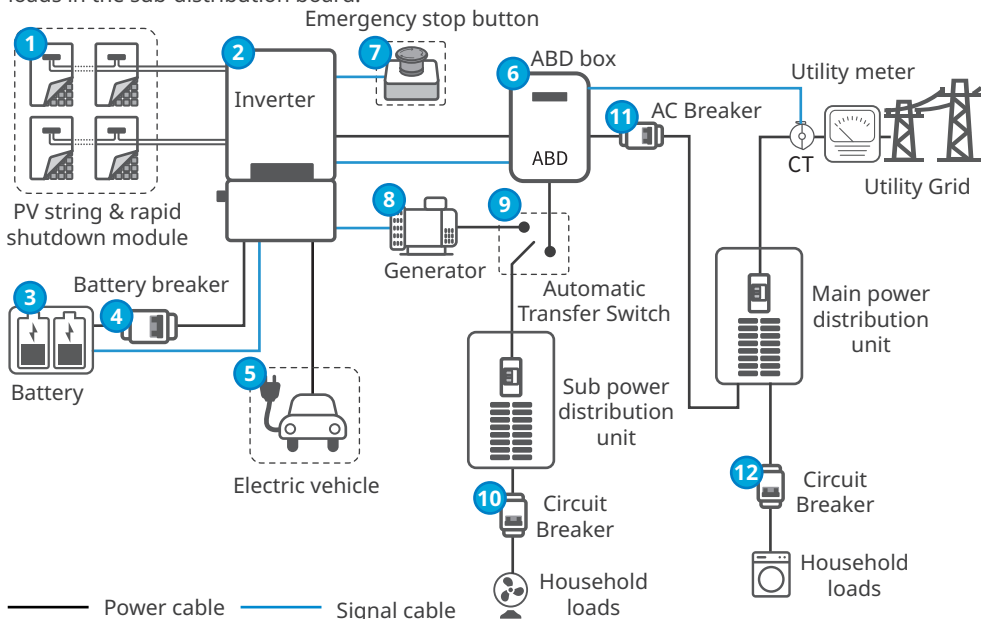

No.	Parts	Description
1	PV string & rapid shutdown module	<ul style="list-style-type: none"> PV String: only for ES series. Rapid shutdown module: only for ES series. Configure the RSD module externally to realize RSD functionality. You can purchase the RSD module from the inverter manufacturer or select RSD-D-XX or Tigo TS4 series from AP Systems. Detailed RSD information supported by the inverter can be obtained from the packing box.
2	Inverter	Support ES and SBP series inverters.
3	Battery	Select the battery model according to the inverter model and the approved battery list.
4	Battery breaker	Recommended specifications: nominal current $\geq 60A$, nominal voltage $\geq 500V$.
5	Electric vehicle	The inverter supports connecting with EV Charger. Configure it according to users' demanding. The Charger purchased from the inverter manufacturer shall meet J1772 (Type1) standard.
6	ABD box	The ABD box can be purchased from the manufacturer. Recommended model: <ul style="list-style-type: none"> ABD100-40-US10, ABD200-40-US10: use with inverter of 5.0-7.6kW rated power. ABD100-63-US10, ABD200-63-US10: use with inverter of 9.6-11.4kW rated power.

No.	Parts	Description
7	Emergency stop button	The inverter supports to connect with emergency stop button. Configure it according to users' demanding. Recommend to use normally closed contact (NC) emergency stop button certified by UL.
8	Generator	The inverter supports to connect with generators. Configure it according to users' demanding. An fully automatic split-phase generator is recommended.
9	Automatic Transfer Switch	When the system is configured with a generator, it shall also use an automatic transfer switch. When the transfer switch detects that the generator has voltage, it will be switched to the generator automatically for load supplying.
10	Load Breaker	Depend on the actual using load.
11	AC Breaker	Optional in compliance with local laws and regulations. Requirements are recommended: 200A rated, UL listed.
12	Load Breaker	Depend on the actual using load.

Microgrid Solutions

When the power grid is power off, the AC coupled inverter operates in off-grid mode and can form a micro-grid system. The PV grid-tied inverter can operate normally in the microgrid system. When its output power > the household load power, the excess power can charge the battery through the AC-coupled inverter.

 **WARNING**

- When the battery SOC is high and charging, the AC coupled inverter will increase its output frequency while the PV grid-tied inverter will reduce its output power until the battery enters a low power discharging state.
- To ensure a stable operation of the microgrid system, the system configuration shall meet the following requirements:
 1. Only support one PV grid-tied inverter in the microgrid system.
 2. In the microgrid system, ensure the rated output power of the AC coupled inverter is > that of the PV grid-tied inverter; the battery output power > the rated output power of the PV grid-tied inverter.
 3. Ensure the battery voltage in the microgrid system is <405V.
 4. The rated output power of the PV grid-tied inverter shall meet the following over-frequency derating curve.

Over-frequency derating curve

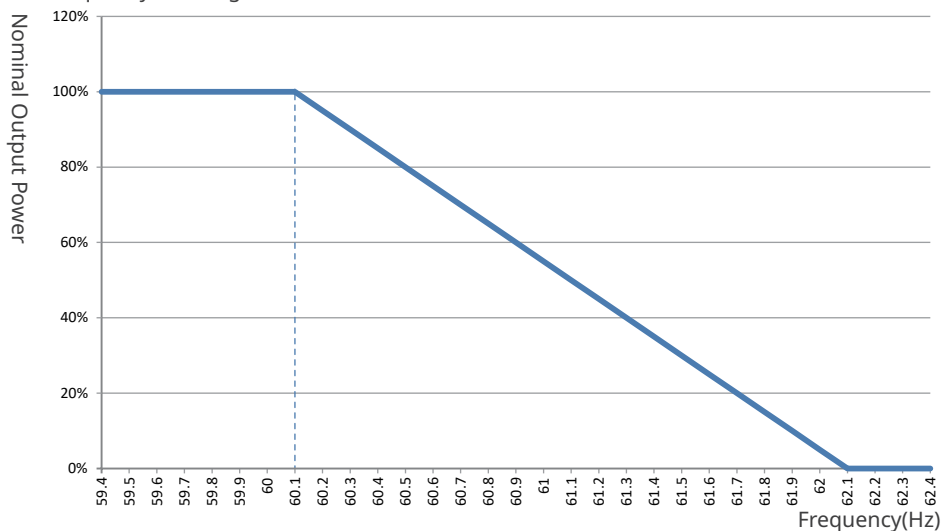

ABD box type I

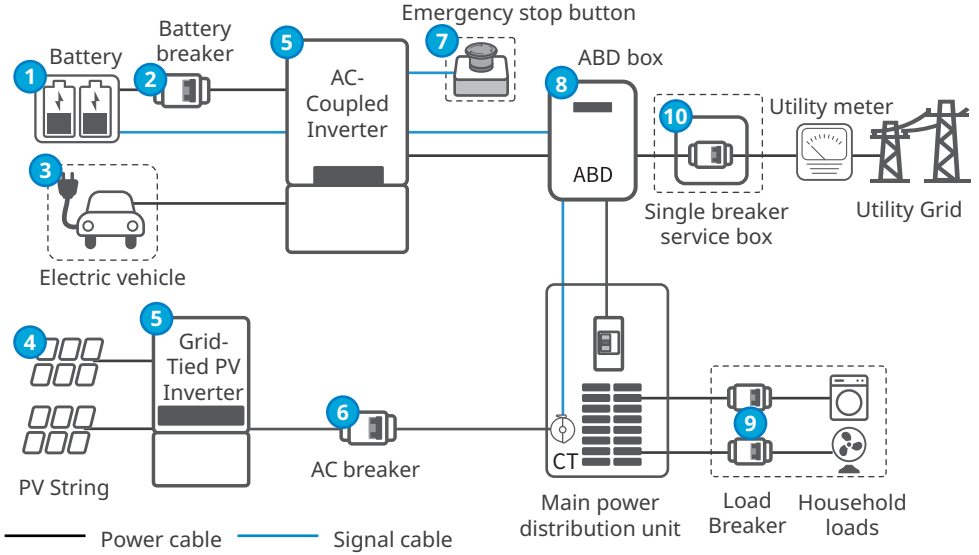

ABD box type II

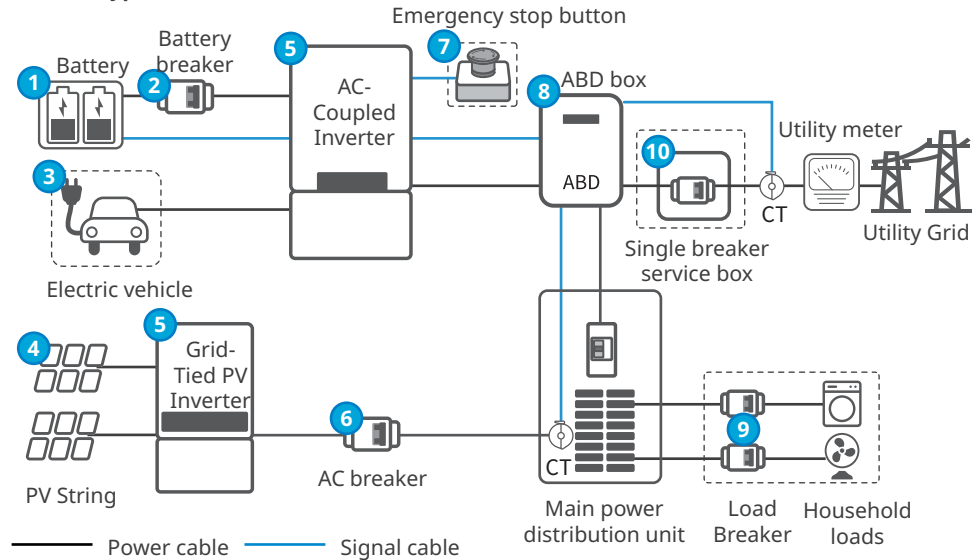

No.	Parts	Description
1	Battery	Select the battery model according to the inverter model and the approved battery list.
2	Battery breaker	Recommended specifications: nominal current \geq 60A, nominal voltage \geq 500V.
3	Electric vehicle	The inverter supports connecting with EV Charger. Configure it according to users' demanding. The Charger purchased from the inverter manufacturer shall meet J1772 (Type1) standard.
4	PV String	PV string is composed of series connected PV panels.
5	Inverter	<ul style="list-style-type: none"> For AC-Coupled Inverter: SBP Series For Grid-Tied Inverter: supporting the third Party's PV inverter.
6	AC breaker	AC output switch specifications of The PV grid-connected inverter depend on the PV inverters' AC output rated current.
7	Emergency stop button	The inverter supports connecting with emergency stop button. Configure it according to users' demanding. Recommend to use normally closed contact (NC) emergency stop button certified by UL.
8	ABD box	<p>The ABD box can be purchased from the manufacturer. Recommended model:</p> <ul style="list-style-type: none"> ABD100-40-US10, ABD200-40-US10: use together with inverter of 5.0-7.6kW rated power. ABD100-63-US10, ABD200-63-US10: use with inverter of 9.6-11.4kW rated power.
9	Load Breaker	Depend on the actual using load.
10	Single breaker service box	Optional in compliance with local laws and regulations. Requirements are recommended: 200A rated, UL listed and Service rated.

3.3 Working Mode

3.3.1 System working mode

Economic mode

NOTICE

- Select Economy mode only when it meets the local laws and regulations, e.g., whether the grid is allowed to charge the battery. If not, do not use this mode.
- It is recommended to use economic mode in scenarios when the difference between peak and valley electricity prices is big.

- Daytime: when the electricity price is in the peak, use the battery to power the load first, and the remaining power can be sold to the grid.
- Night: when the electricity price is in the valley, set the time for the grid to charge the battery.

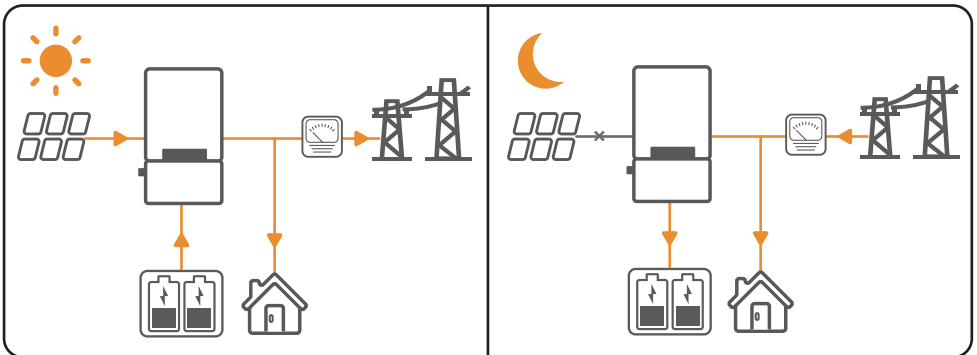

Self consumption mode

NOTICE

- For solar power, consider self consumption mode as priority: the excess power charges the battery in day time; the battery supplies power to the load when there is no solar power generated at night. It improves the self consumption rate and saves electricity costs.
- It is suitable for areas with high electricity prices and little or no solar power generation subsidies.

- Day time:
 - When the power generated in the PV system is sufficient, it supplies the household load as priority. And the excess power charges the batteries first. The remaining power will be sold to the grid.
 - When the power generated in the PV system is insufficient, use the battery supplies the load first. If the battery power is insufficient, then the load will be provided by the grid.
- Night time:

If the battery power is sufficient, the load will be powered by the battery. If the battery power is not enough, the load will be powered by the grid.

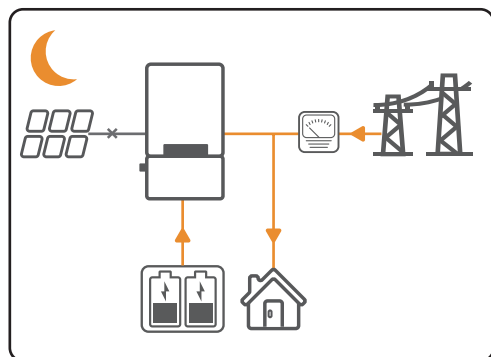
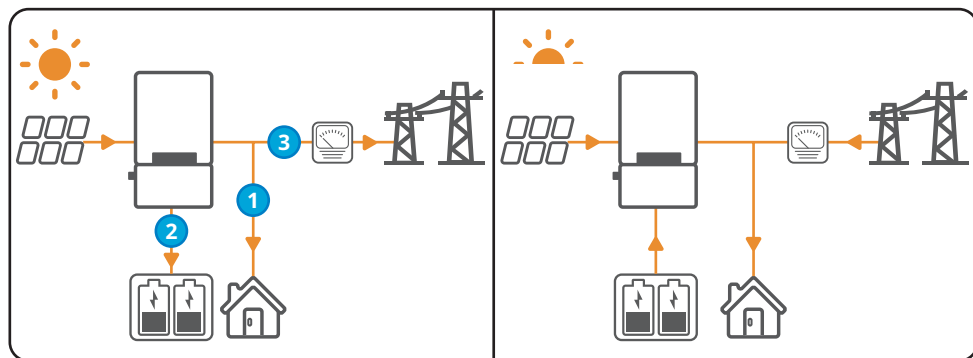

Back-up mode

NOTICE

- The back-up mode is mainly applied to the scenario where the grid is unstable and there is an important load. When the grid is power off, the inverter turns to off-grid mode to supply power to the load; when the grid is restored, the inverter switches to on-grid mode.
 - The battery stops discharging when it reaches SOC. When there is light the next day, the battery starts to supply power to the load after it is charged to a certain power level.
- When the power generated in the PV system is sufficient, it charges the battery as priority. And the excess power charges the load. The remaining power will be sold to the grid.
 - When there is no power generated in the PV system:
 - The grid charges the battery and supplies the load at the same time when the power grid is normal. (Please do not use this scenario if local laws and regulations do not allow the grid to charge the battery.)
 - The inverter enters off-grid mode and the battery supplies power to the load when the grid is abnormal.

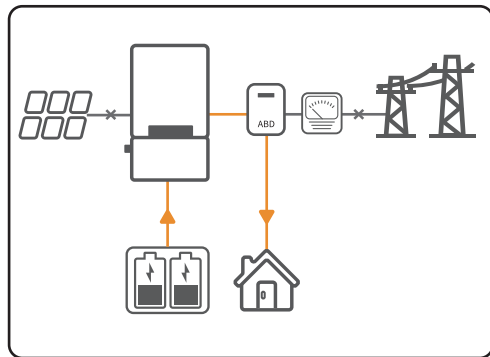
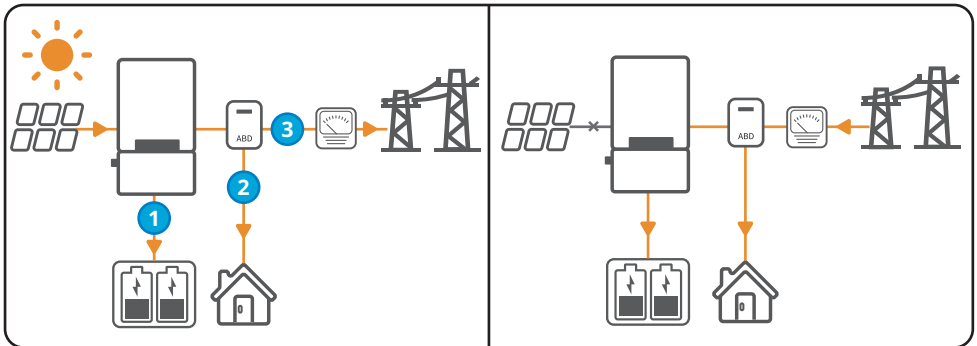

3.3.2 EV Charger Working Mode

NOTICE

- The power to charge the EV may come from the PV system, the battery or the grid. The specific power source is determined by the system working mode.
- The Reserved Charging and PV Charging Only modes can be selected at the same time. It supports the Full Power Charging mode during the reserved time; while beyond the appointment time and the Full Power Charging mode is not selected, the system will be in the PV Charging Only mode.

Full power charging mode (default mode)

Select this mode and it starts charging the moment the charger is inserted into the EV.

Reserved charging mode

Select this mode and the system charges the EV at the maximum power of the charger within the setting time.

PV charging only mode

- When the power generated in the PV system is sufficient, it charges the household load as priority. The rest power will be provided to EV, battery and grid one by one.
- When the power generated in the PV system is insufficient, that is when the power generated in the PV system is $<$ household load, it stops charging the EV.

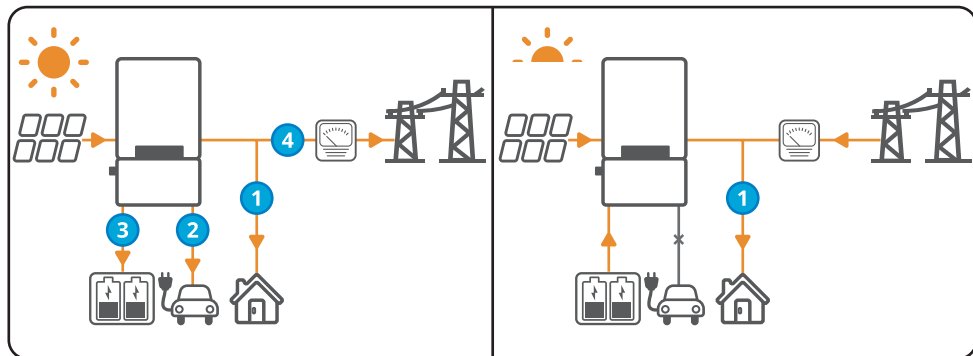

3.3.3 Inverter operation mode

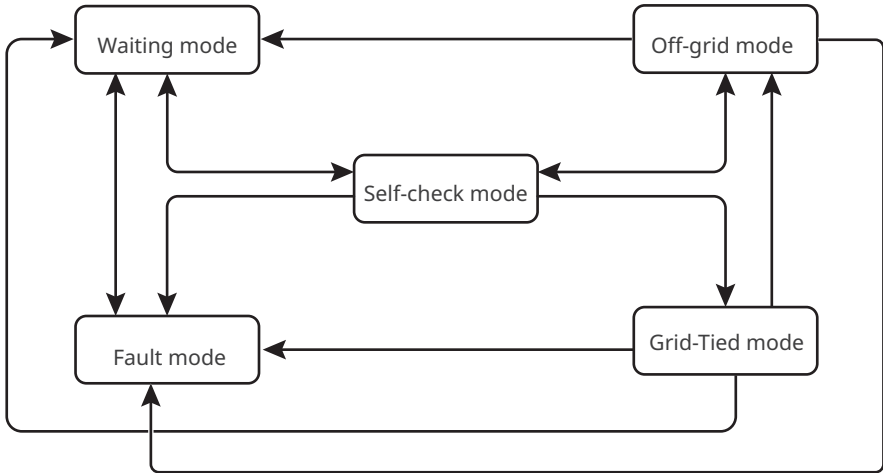

No.	Parts	Description
1	Waiting mode	Waiting stage after the inverter is powered on. <ul style="list-style-type: none"> When the conditions are met, it enters the self-check mode. If there is a fault, the inverter enters the fault mode.
2	Self-check mode	Before the inverter starts up, it continuously performs self-check, initialization, etc. <ul style="list-style-type: none"> When the conditions are met, it enters the grid-tied mode, and the inverter starts on grid connection. If the grid is not detected, it enters the off-grid mode and the inverter runs off-grid; if the inverter has no off-grid function, it enters the wait mode. If the self-check is not passed, it enters the fault mode.
3	Grid-Tied mode	The inverter is grid-tied successfully. <ul style="list-style-type: none"> If the grid is not detected, it enters the off-grid mode. If a fault is detected, it enters the fault mode. If the conditions do not meet grid-tied requirements and the off-grid output function is not turned on, it enters the wait mode.
4	Off-grid mode	When the grid is powered off, the inverter switches to the off-grid mode and continues to supply power to the load. <ul style="list-style-type: none"> If a fault is detected, it enters the fault mode. If the conditions do not meet grid-tied requirements and the off-grid output function is not turned on, it enters the wait mode. If the conditions meet grid-tied requirements and the off-grid output function is turned on, it enters the self-check mode.
5	Fault mode	If a fault is detected, the inverter enters the fault mode. When the fault is cleared, it enters the wait mode.

3.4 Functionality

EV Charger

- The inverter has a built-in connection port for charging EV. This port is compatible with the J1772 (Type1) specification and meets the AC Level 2 standard. It is applicable to EVs with J1772 (Type1) sockets. It uses energy from the PV system to charge the EV in a flexible, convenient and reliable way.
- EV Charger supports full power charging (default), reserved charging and PV charging only modes.

Power derating

For a safe operation, the inverter will automatically reduce the output power when the operating environment is not ideal.

The following are the factors that may occur power derating. Please try to avoid them during usage.

- Unfavorable environmental conditions, e.g., direct sunlight, high temperature, etc.
- Inverter's output power percentage has been set.
- Over-frequency derating.
- Higher input voltage value.
- Higher input current value.

AFCI

Reason to occur electric arcs.

- Damaged connectors in PV or battery system
- Wrong connected or broken cables
- Aging connectors and cables

Method to detect electric arcs

- The inverter has an integrated AFCI function and meets UL/CSA (UL1699B) standards.
- When the inverter detects an electric arc, users can find the time of the fault and the detailed phenomenon through the app.
- The alarm can be cleared automatically if the inverter triggers a fault for less than 5 times within 24 hours. The inverter locks for protection after the 5th electric arc fault. The inverter can operate normally after the fault is solved. Please refer to the SolarGo App User Manual for detailed operation.

Load Control

The inverter reserves a dry contact controlling port, which supports connecting additional contactors to enable/disable the load.

The load control methods are as follows:

- Time control: set the time to enable/disable the load, and the load will be turned on or off automatically within the setting time period.
- Switch control: when the control mode is selected as ON, the load will be enabled; when it is set as OFF, the load will be disabled.
- BACK-UP load control: the inverter has built-in DO dry contact controlling port, which can control whether the load is off or not by contactor. In off-grid mode, the load connected to the DO port can be turned off if the overload at the BACK-UP end is detected or the battery SOC value is lower than the battery off-grid protection setting.

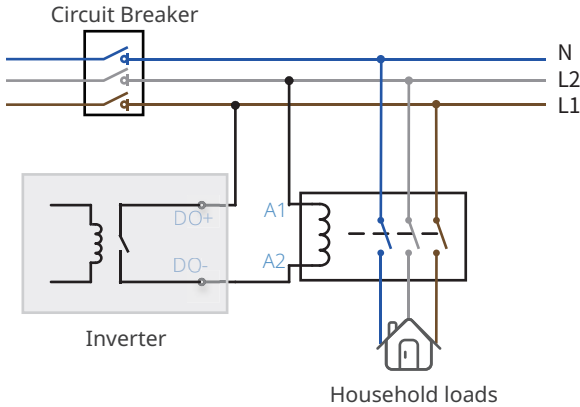

Ezlink

The inverter has a built-in Ezlink module supporting IEEE2030.5 communication protocol. It supports setting the inverter via Bluetooth in a short distance; connecting to the server via 4G, WiFi or LAN to monitor the inverter and power plant operation, etc.

- Bluetooth: meets Bluetooth 5.1 standard
- 4G (optional): supports AT&T and T-Mobile mainstream service provider.
- WiFi: supports 2.4G frequency band. Set the router to 2.4G or 2.4G/5G coexistence mode (User can set 40 bytes for router wireless signal name maximumly.)
- LAN (optional): supports connecting to the router via LAN communication and then connecting to the server.

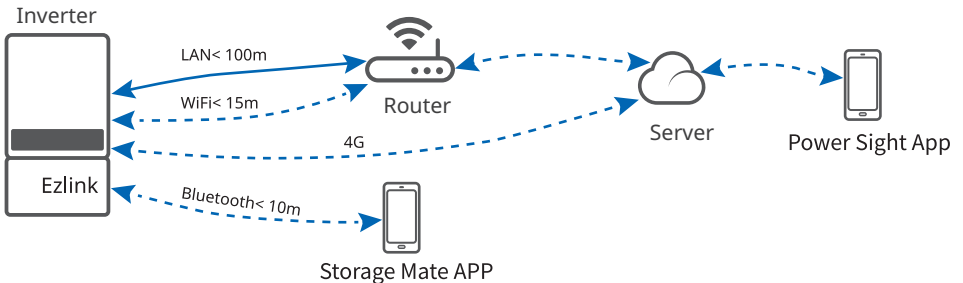

3.5 Appearance

3.5.1 Parts

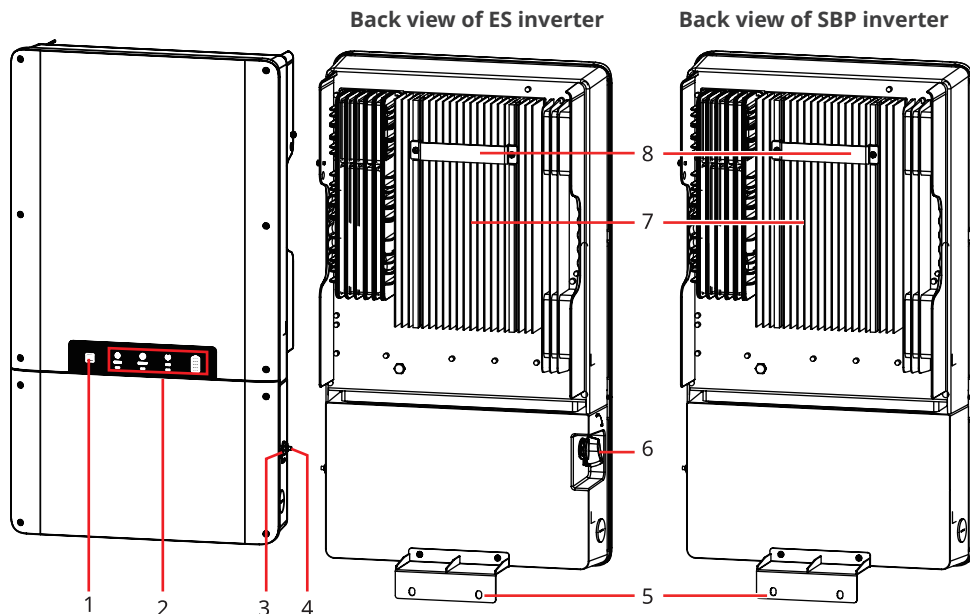





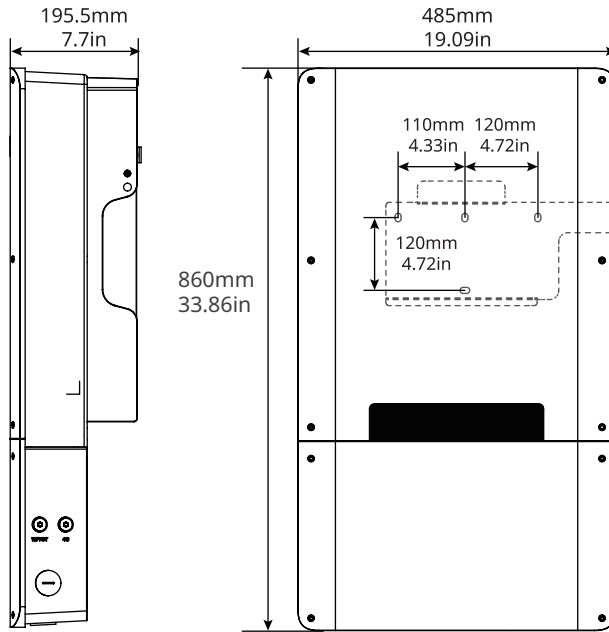











No.	Parts	Description
1	Restarting button for the communication module	Restart the communication module
2	LED Indicator	Refers to the inverter's working status
3	Port for WiFi/BT antenna	To connect with WiFi/BT antenna
4	Port for 4G antenna	To connect with 4G antenna
5	Inverter fixing part	To fix the inverter
6	DC Switch	Start or stop DC input
7	Heat sink	A device to radiate the inverter's heat
8	Mounting Plate	Used to install the inverter.

3.5.2 Dimension









3.5.3 Indicators

Indicator	Status	Explanation
		The inverter is power on and in the standby mode.
		The inverter is starting up and in the self-check mode.
		The inverter is in normal operation under grid-tied or off-grid modes.
		BACK-UP output overload
		A fault has occurred.
		The inverter is powered off.
		The grid is abnormal and the inverter is in off-grid mode.
		The grid is normal and the inverter is in grid-tied mode.
		BACK-UP is off.
		The monitoring module of the inverter is resetting.
		The inverter fails to connect with Termination.
		Communication fault between Termination and Server.
		The monitoring of the inverter operates well.
		The monitoring module of the inverter has not been started yet.

3.5.4 Nameplate

The nameplate is for reference only.

Product: Hybrid Inverter Model : GW5000-ES-US20		GW trademark, product type, and product model
PV voltage: Max. 600Vd.c., MPPT range 50...550Vd.c. PV current: Max. 2*16Ad.c., Isc 2*23,4Ad.c.		
Battery voltage range: 80...495Vd.c. Battery max. charge/discharge current: 50/50Ad.c. Battery type: Li-Ion, Minimum interrupting rating: 50Ad.c.		
On-grid nominal output voltage: 211...264@240Va.c.,60Hz On-grid frequency range: 58.5...61,2Hz, Max backfeed: 0Aa.c. On-grid output max. current: 20,8Aa.c. On-grid max. current from grid without EV Charger: 20,8Aa.c. On-grid max. current from grid with EV Charger: 40Aa.c. On-grid output rated active power: 5kW On-grid output max. apparent power: 5kVA On-grid max. apparent power from grid without EV Charger: 5kVA On-grid nominal apparent power from grid with EV Charger: 9,6kVA		Technical parameters
Back-up nominal output voltage: 120/240Va.c., 60Hz Back-up max. output current: 20,8Aa.c. Back-up max. output apparent power: 5kVA		
Optional: EV charge output rated AC power: 9,6kW EV charge output max. current: 40Aa.c. EV charge voltage: 240Va.c., 60Hz, EV charge level: AC Level 2		
Derating temperature: 113°F(45°C) Power factor range: ~1,0,8cap...0,8ind Operating temperature range: -31°F ~ 140°F(-35°C~60°C) Grid Support Utility Interactive Inverter transformerless Type 4X, PV DC AFCI: Type 1, Contains FCC ID: 2AU7JEzink3000-US		
		Safety symbols and certification marks
S/N: <div style="text-align: center;">  </div>		
Made in China		Contact information and serial number
GoodWe Technologies Co., Ltd. service@goodwe.com No.90 Zijin Rd., New District, Suzhou, 215011, China		S/N

4 Check and Storage

4.1 Check Before Receiving

Check the following items before receiving the product.

1. Check the outer packing box for damage, such as holes, cracks, deformation, and others signs of equipment damage. Do not unpack the package and contact the supplier as soon as possible if any damage is found.
2. Check the inverter model. If the inverter model is not what you requested, do not unpack the product and contact the supplier.
3. Check the deliverables for correct model, complete contents, and intact appearance. Contact the supplier as soon as possible if any damage is found.

4.2 Deliverables

WARNING

Connect the DC cables with the delivered terminals. The manufacturer shall not be liable for the damage if other terminals are used.

NOTICE

- 4G or WiFi antenna is shipped according to the communication mode supported by the inverter.
- The number of expansion bolts shipped with the packing box may differ depending on inverter types. Please refer to the actual situation.
- PV DC terminals are only distributed for hybrid inverters. Its distributed quantity matches the number of PV strings supported by the inverter.

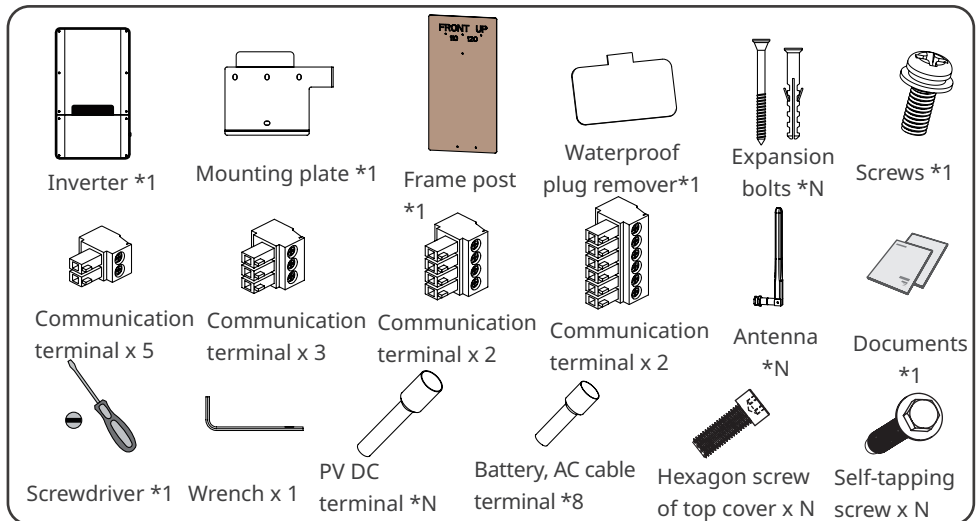

4.3 Storage

If the equipment is not to be installed or used immediately, please ensure that the storage environment meets the following requirements:

1. Do not unpack the outer package or throw the desiccant away.
2. Store the equipment in a clean place. Make sure the temperature and humidity are appropriate and no condensation.
3. The height and direction of the stacking inverters should follow the instructions on the packing box.
4. The inverters must be stacked with caution to prevent them from falling.
5. If the inverter has been long term stored, it should be checked by professionals before being put into use.

5 Installation

5.1 Installation Requirements

Installation Environment Requirements

1. Do not install the equipment in a place near flammable, explosive, or corrosive materials.
2. Do not install the equipment in a place that is easy to touch, especially within children's reach. High temperature exists when the equipment is working. Do not touch the surface to avoid burning.
3. Avoid the water pipes and cables buried in the wall when drilling holes.
4. Install the equipment in a sheltered place to avoid direct sunlight, rain, and snow. Build a sunshade if it is needed.
5. The place to install the equipment shall be well-ventilated for heat radiation and large enough for operations. The distance from the charger to the ground shall not be less than 600mm(23.62in).
6. The equipment with a high ingress protection rating can be installed indoors or outdoors. The temperature and humidity at the installation site should be within the appropriate range.
7. Install the equipment at a height that is convenient for operation and maintenance, electrical connections, and checking indicators and labels.
8. The altitude to install the inverter shall be lower than the maximum working altitude 3000m(9842ft).
9. Install the equipment away from electromagnetic interference. If there are radio stations or wireless communication equipment below 30 MHz near the installation location, please install the equipment as follows:
 - Add a multi-turn winding ferrite core at the DC input line or AC output line of the inverter, or add a low-pass EMI filter.
 - The distance between the inverter and the wireless EMI equipment is more than 30m.

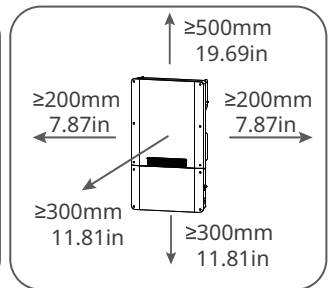
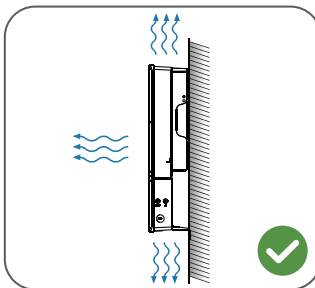
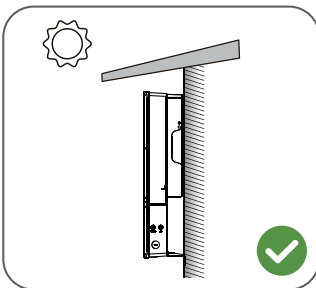
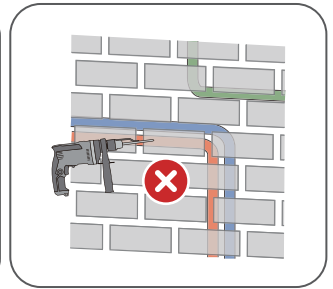
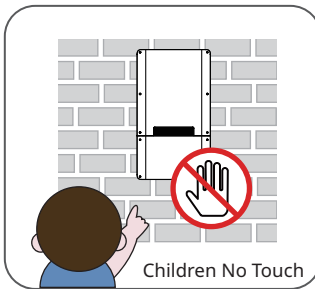
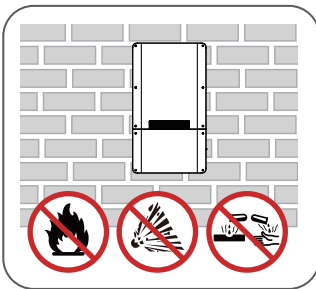

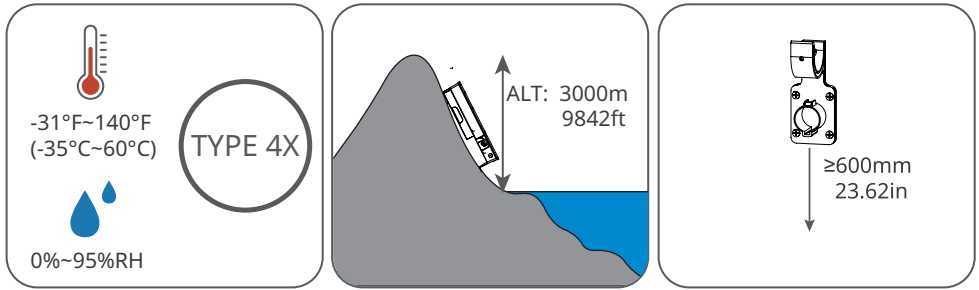

Mounting Support Requirements

- The mounting support shall be nonflammable and fireproof.
- Install the equipment on a surface that is solid enough to bear the inverter weight.
- Do not install the product on the support with poor sound insulation to avoid the noise generated by the working product, which may annoy the residents nearby.





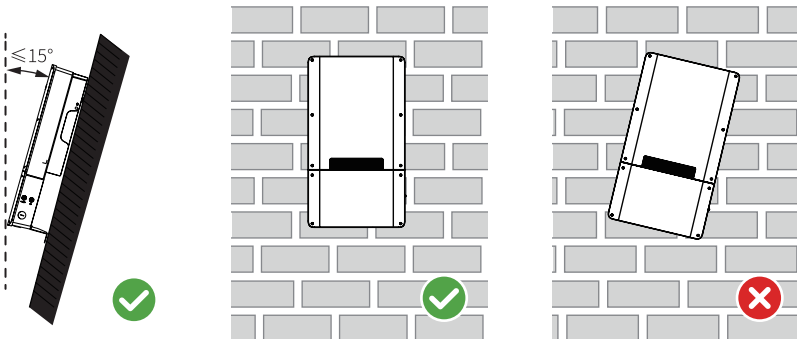

Installation Angle Requirements

- Install the inverter vertically or at a maximum back tilt of 15 degrees.
- Do not install the inverter upside down, forward tilt, back forward tilt, or horizontally.

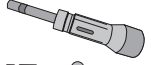

Installation Tool Requirements

The following tools are recommended when installing the equipment. Use other auxiliary tools on site if necessary.

 Goggles	 Safety shoes	 Safety gloves	 Dust mask	 RJ45 crimping tool
 Diagonal pliers	 Wire stripper	 Hammer drill	 Heat gun	 Vacuum cleaner
 Marker	 Level	 Heat shrink tube	 Rubber hammer	 Torque wrench M3/M5
 Multimeter	 Cable tie			

5.2 Inverter Installation

5.2.1 Moving the Inverter



CAUTION

- Operations such as transportation, turnover, installation and so on must meet the requirements of the laws and regulations of the country or region where it is located.
- Move the inverter to the site before installation. Follow the instructions below to avoid personal injury or equipment damage.
 1. Consider the weight of the equipment before moving it. Assign enough personnel to move the equipment to avoid personal injury.
 2. Wear safety gloves to avoid personal injury.
 3. Keep the equipment in balance during moving to avoid its falling down.

5.2.2 Installing the Inverter

NOTICE

- Avoid the water pipes and cables buried in the wall when drilling holes.
- Wear goggles and a dust mask to prevent the dust from being inhaled or contacting eyes when drilling holes.
- The DC switch lock of appropriate size should be prepared by customers. Diameter of the lock hole is $\varnothing 8\text{mm}$ (0.31in). Choose the appropriate size. Otherwise, it might not be able to install. (Supported by mixed inverter only.)
- The anti-theft lock of appropriate size should be prepared by customers. Diameter of the lock hole is $\varnothing 10\text{mm}$ (0.39in). Choose the appropriate size. Otherwise, it might not be able to install.
- Make sure the inverter is firmly installed in case of falling down.

Installing the Inverter (concrete wall)

Expansion bolts are recommended when the inverter is installed on a concrete wall.

Step 1: Put the frame post on the wall horizontally and mark positions for drilling holes. (If you choose EV Charger function, please also determine the of the punching holes' location for the charger mounting bracket.)

Step 2: Drill holes by using the hammer drill.

Step 3: Use the expansion bolts to fix the mounting plate and the charger bracket on the wall.

Step 4: (Optional) Secure the DC switch with the DC switch lock, ensuring that the DC switch is "OFF" during installation.

Step 5: Install the inverter on the mounting plate.

Step 6: Tighten the nuts to secure the mounting plate and the

Step 7: Install the anti-theft lock.

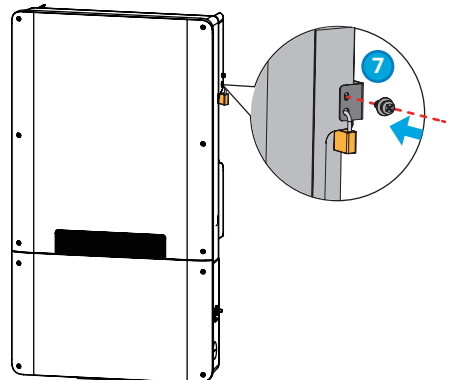
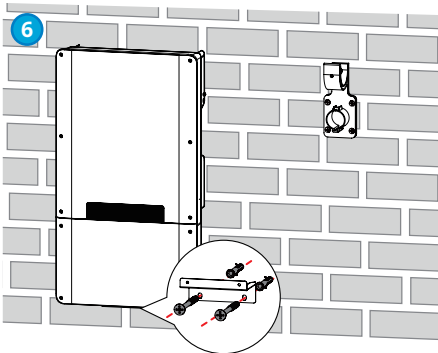
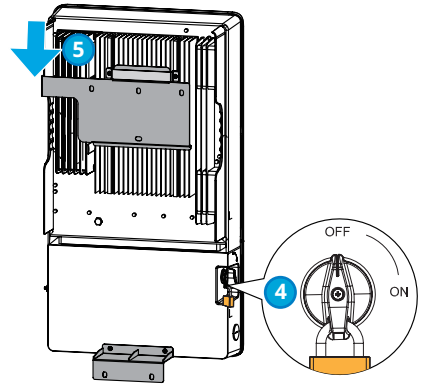
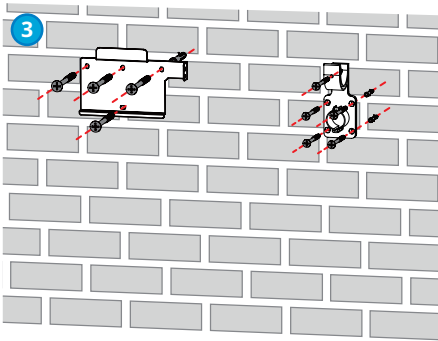
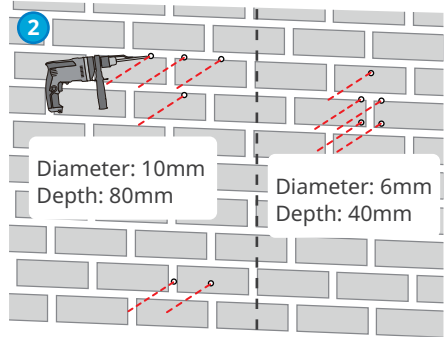
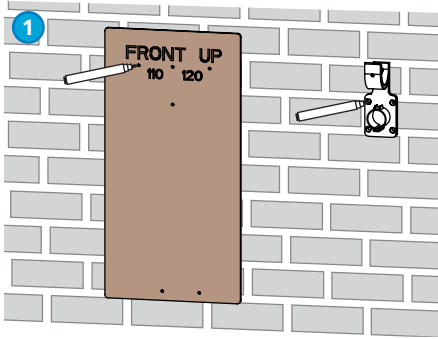

Installing the Inverter (wooden wall)

Self-tapping screws are recommended when the inverter is installed on a wooden wall.

Step 1: Put the frame post on the wall horizontally and mark positions for drilling holes. (If you choose EV Charger function, please also determine the of the punching holes' location for the charger mounting bracket.)

Step 2: Use the self-tapping screws to fix the mounting plate and the charger bracket on the wall.

Step 3: (Optional) Secure the DC switch with the DC switch lock, ensuring that the DC switch is "OFF" during installation.

Step 4: Install the inverter on the mounting plate.

Step 5: Tighten the nuts to secure the mounting plate and the

Step 6: Install the anti-theft lock.

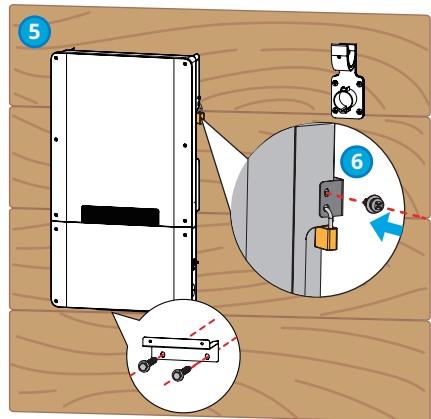
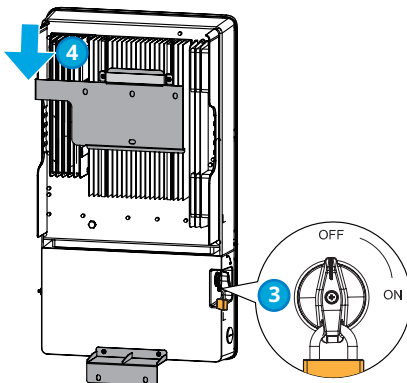
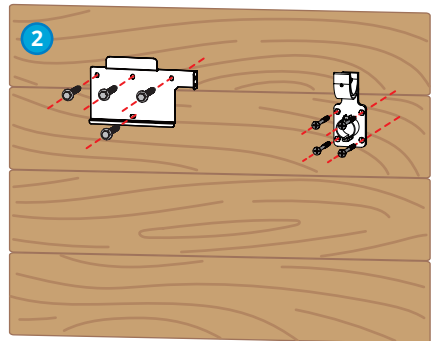
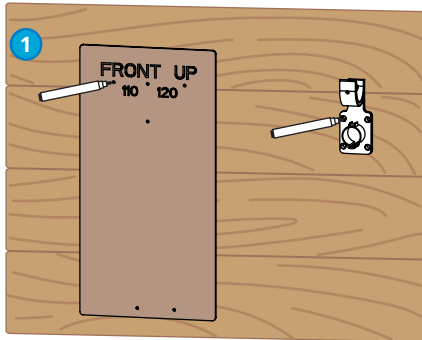

6 Electrical Connection

6.1 Safety Precaution



DANGER

INSTRUCTIONS PERTAINING TO A RISK OF FIRE OR ELECTRIC SHOCK

- All operations, cables and parts specification during the electrical connection shall be in compliance with local laws and regulations.
- The input and output circuits are isolated from the enclosure and that system grounding, if required by the National Electric Code, ANSI/NFPA 70, is the responsibility of the installer.
- Disconnect the DC switch and the AC output switch of the inverter to power off the inverter before any electrical connections. Do not work with power on. Otherwise, an electric shock may occur.
- Tie the same type cables together, and place them separately from cables of different types. Do not place the cables entangled or crossed.
- If the cable bears too much tension, the connection may be poor. Reserve a certain length of the cable before connecting it to the inverter cable port.
- When crimping the terminals, ensure that the conductor part of the cable is in full contact with the terminals. Do not crimp the cable jacket with the terminal. Otherwise the inverter may not operate, or its terminal block getting damaged due to heating and other phenomenon because of unreliable connection after operation.



WARNING

GROUNDING INSTRUCTIONS

This product must be connected to a grounded, metal, permanent wiring system, or an equipment-grounding conductor must be run with the circuit conductors and connected to the equipment grounding terminal or lead on the product.

NOTICE

- Wear personal protective equipment like safety shoes, safety gloves, and insulating gloves during electrical connections.
- All electrical connections should be performed by qualified professionals.
- Cable colors in this document are for reference only. The cable specifications shall meet local laws and regulations.

6.2 Preparations before Installation

6.2.1 Terminal introduction

WARNING

- The watertight conduit needs to be provided by the user, and the specification of the watertight conduit used shall match the specification of the waterproof plug.
- Below is the diameter for the routing hole on the bottom of the inverter. Recommend to use 1 inch cable gland for routing.
- When installing the watertight conduit, make sure the installation is in place and the hole between the watertight conduit and the inverter interface is sealed. Otherwise the protection level of the equipment may be affected, which may cause damage to the equipment.

Diameter for the inverter routing hole

- Electric vehicle: $D = 32\text{mm}(1.26\text{in})$
- Others $D = 34\text{mm}(1.34\text{in})$

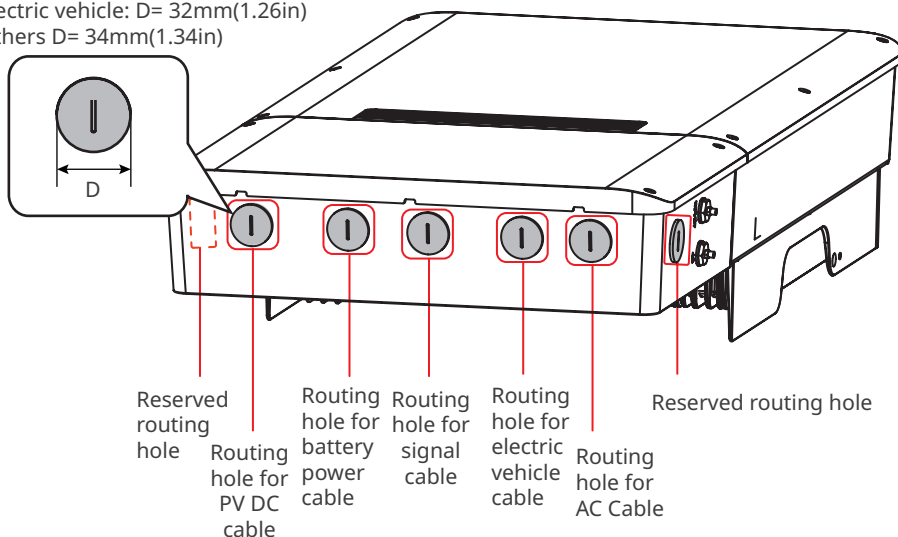

6.2.2 Cable Specification

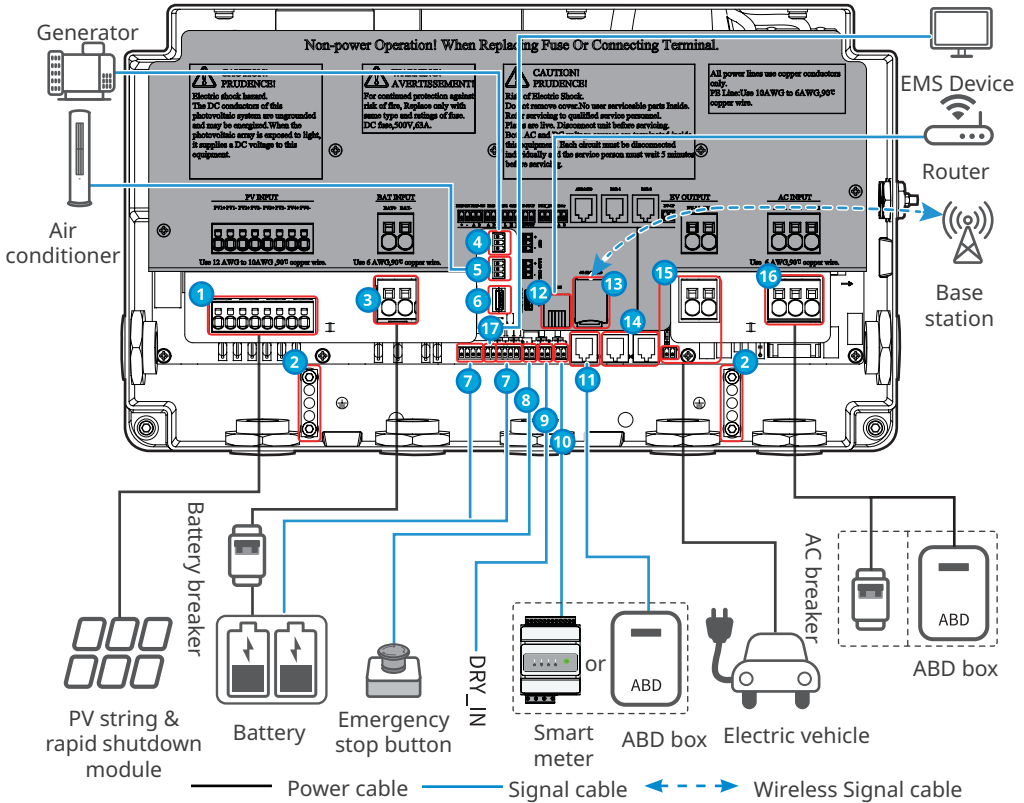

No.	Port	Screen print	Explanation
1	DC Input Port	PV INPUT	<ul style="list-style-type: none"> Connect with PV DC input cable(only support hybrid inverters) The recommended cables are: copper wire, temperature 90°C(194°F), 12-10AWG
2	Grounded bus bar	-	<ul style="list-style-type: none"> Connecting the PE cable The recommended cables are: copper wire, temperature 90°C(194°F), 10-6AWG
3	Battery cable port	BAT INPUT	<ul style="list-style-type: none"> Connect with battery DC cable The recommended cables are: copper wire, temperature 90°C(194°F), 6AWG
4	Generator start/stop controlling port	GEN	<ul style="list-style-type: none"> Connect with the generator's communication cable Recommended cable specification: 24-16AWG, communication cables for outdoors which are satisfying UL2919, CM/CMG(NEC type) or CMH (CSA type) standards

No.	Port	Screen print	Explanation
5	Load control port	LOAD CNTL	<ul style="list-style-type: none"> Connect with the load controlling cable Recommended cable specification: 24-16AWG, communication cables for outdoors which are satisfying UL2919, CM/CMG(NEC type) or CMH (CSA type) standards
6	USB COM Port	U DISK	The inverter supports connecting with U Disk to upgrade the software of the inverter.
7	Battery COM Port	EMS/CAN	<ul style="list-style-type: none"> Connect with battery DC cable <ul style="list-style-type: none"> BMS-EN port: connect with LG battery BMS-485 port: connect with batteries supporting RS 485 communications CAN1 port: connect with batteries supporting CAN communications CAN2 port: reserved Recommended cable specification: 24-16AWG, communication cables for outdoors which are satisfying UL2919, CM/CMG(NEC type) or CMH (CSA type) standards
8	Emergency stop button I/O port	E-STOP	<ul style="list-style-type: none"> Connect with Emergency stop button Recommended cable specification: 24-16AWG, communication cables for outdoors which are satisfying UL2919, CM/CMG(NEC type) or CMH (CSA type) standards
9	Dry contact port	DRY_IN	<ul style="list-style-type: none"> Connect with devices supporting dry contact communication Recommended cable specification: 24-16AWG, communication cables for outdoors which are satisfying UL2919, CM/CMG(NEC type) or CMH (CSA type) standards
10	Meter COM Port	Meter	<ul style="list-style-type: none"> Connect with meter communication cable Recommended cable specification: 24-16AWG, communication cables for outdoors which are satisfying UL2919, CM/CMG(NEC type) or CMH (CSA type) standards
11	ABD/MPD COM Port	ABD/MPD	<ul style="list-style-type: none"> Connect with ABD/MPD box communication cable. There is no need to connect with the meter when it configures with ABD box. Recommended cable specification: CAT 5E outdoor shielded network cable and shielded RJ45 connector

No.	Port	Screen print	Explanation
12	LAN COM Port	LAN	<ul style="list-style-type: none"> • Connect with the router's communication cable, then connect with the monitoring platform on the server • Recommended cable specification: CAT 5E outdoor shielded network cable and shielded RJ45 connector
13	SIM card installation port	4G SIM CARD	Optional. The inverter supporting 4G communication can install SIM card to connect with the monitoring platform on the server.
14	Parallelized operation COM Port	PAR-1, PAR-2	Reserved
15	Charger wiring port	EV OUTPUT	<ul style="list-style-type: none"> • Connect the Electric vehicle charger • If you purchase the charger from the inverter manufacturer, the cable will be included in its packing list. • If you buy the charger by your own, the cable shall be prepared by yourself.
16	AC cable wiring port	AC INPUT	<ul style="list-style-type: none"> • Connect with the inverter's AC cable. There is no need to connect with AC switch when it configures with ABD box. • The recommended cables are: copper wire, temperature 90°C(194°F) <ul style="list-style-type: none"> • 5.0-7.6kW: 7-8 AWG • 9.6kW: 6-7 AWG • 11.4kW: 5-6 AWG
17	EMS COM Port	EMS	Connect with the third party device

6.3 Opening the wiring cover

NOTICE

- The wrench for opening the inverter lower case cover is distributed with the inverter. After removing the inverter lower case cover, please keep the wrench and fastening screws properly for later use.
- If you need to open the inverter cover in rain or snow, please take protective measures to prevent rain or snow from entering the maintenance chamber. If it is not able to be guaranteed, do not open the inverter cover.
- It is forbidden to open the inverter upper case cover.

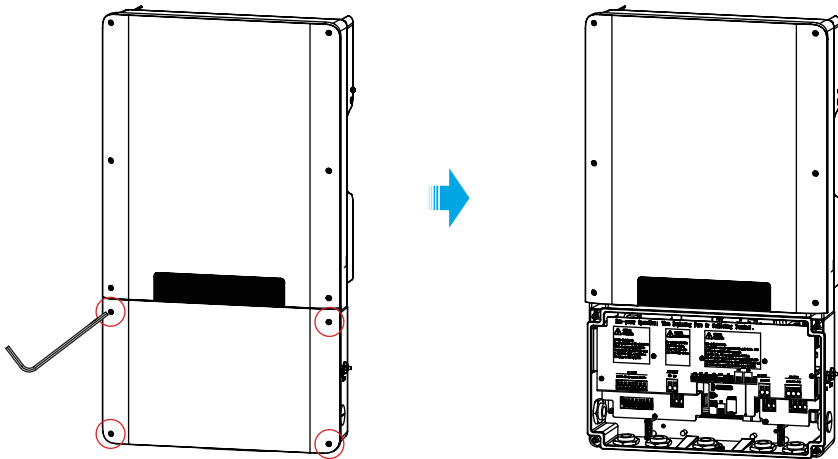

6.4 Connecting the DC Input Cable(PV)

NOTICE

Only Hybrid Inverter supporting DC Input Cable connection

! DANGER

INSTRUCTIONS PERTAINING TO A RISK OF FIRE OR ELECTRIC SHOCK

- Do not connect one PV string to more than one inverter at the same time. Otherwise, it may cause damage to the inverter.
- Confirm the following information before connecting the PV string to the inverter. Otherwise, the inverter may be damaged permanently or even cause fire and cause personal and property losses.
 1. Make sure that the max short circuit current and the max input voltage per MPPT are within the permissible range.
 2. Make sure that the positive pole of the PV string connects to the PV+ of the inverter. And the negative pole of the PV string connects to the PV- of the inverter.

! WARNING

- The PV strings cannot be grounded. Ensure the minimum insulation resistance of the PV string to the ground meets the minimum insulation resistance requirements before connecting the PV string to the inverter ($R > 100k\Omega$). If the insulation resistance value is $\leq 100k\Omega$, it will trigger the insulation resistance alarming in the inverter.
- The unit is not provided with an isolation transformer and is intended to be installed per NFPA 70, 690.35 with an ungrounded PV array.

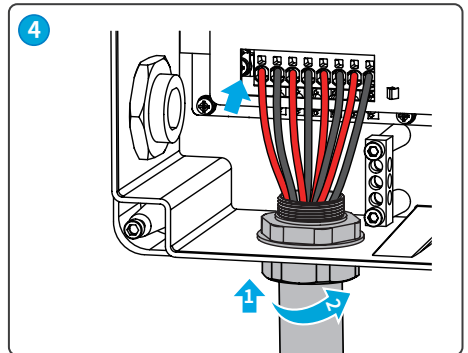
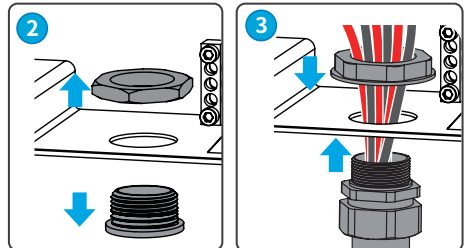
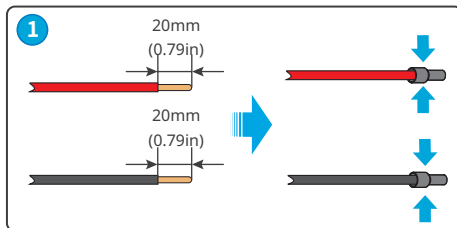
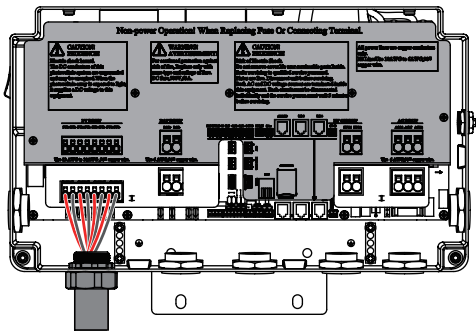

6.5 Connecting the battery cable



DANGER

INSTRUCTIONS PERTAINING TO A RISK OF FIRE OR ELECTRIC SHOCK

- The battery used with the inverter shall be approved by the inverter manufacturer. The approved battery list can be obtained through the official website.
- A short circuit in the battery may cause personal injury. The instantaneous high current caused by a short circuit can release a large amount of energy and may cause a fire.
- Before connecting the battery cable, ensure the inverter and the battery, and downstream&upstream switches, are all disconnected.
- It is forbidden to connect and disconnect the battery cables when the inverter is running. Otherwise it may cause electric shock.
- Do not connect one battery group to more than one inverter at the same time. Otherwise, it may cause damage to the inverter.
- It is forbidden to connect loads between the inverter and batteries.
- When connecting battery cables, use insulated tools to prevent accidental electric shock or short circuit to the batteries.
- Ensure that the open circuit voltage of the battery is within the permissible range of the inverter.
- Install a DC switch between the inverter and the battery.



WARNING

- Connect the battery cables to the corresponding terminals such BAT+, BAT- and grounding ports correctly. Otherwise it will cause damage to the inverter.
- Ensure that the whole cable cores are inserted into the terminal holes. No part of the cable core can be exposed.
- Ensure that the cables are connected securely. Otherwise it will cause damage to the inverter due to overheat during its operation.

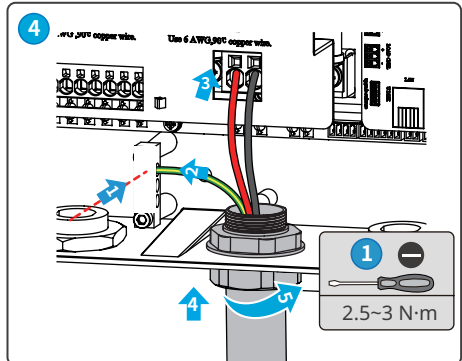
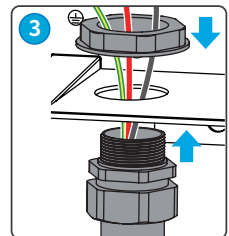
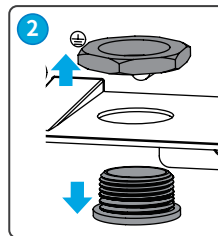
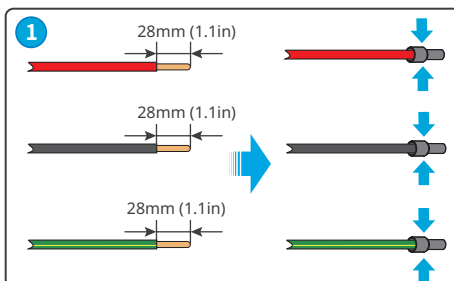
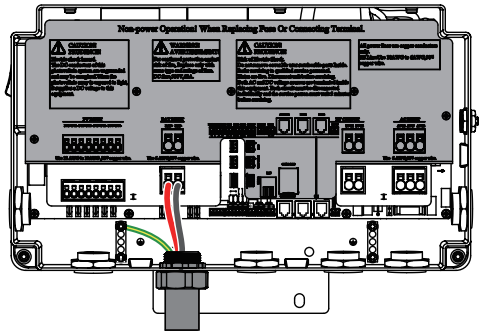

6.6 Connecting the AC Cable

WARNING

Do not connect loads between the inverter and the AC switch directly connected to the inverter.

NOTICE

- Install one AC circuit breaker for each inverter. Multiple inverters cannot share one AC circuit breaker.
- An AC circuit breaker shall be installed on the AC side to ensure that the inverter can be safely disconnected with the grid when there is abnormal. Select the appropriate AC circuit breaker in compliance with local laws and regulations.

WARNING

- Connect the AC cables to the corresponding terminals such as L1, L2, N, and grounding ports correctly. Otherwise it will cause damage to the inverter.
- Ensure that the whole cable cores are inserted into the terminal holes. No part of the cable core can be exposed.
- Ensure that the cables are connected securely. Otherwise it will cause damage to the inverter due to overheat during its operation.

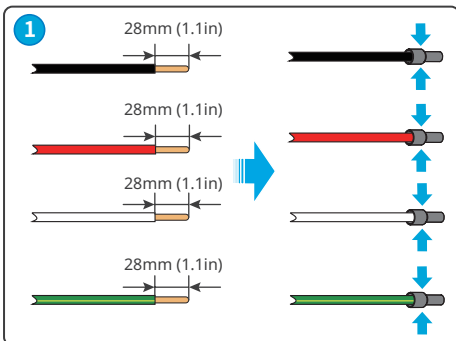
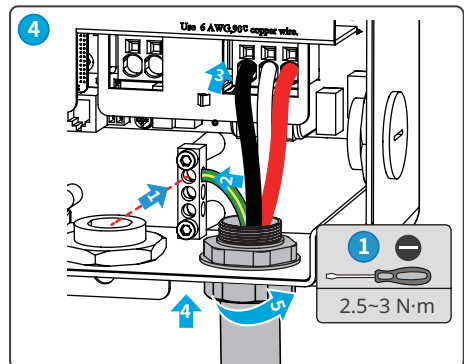
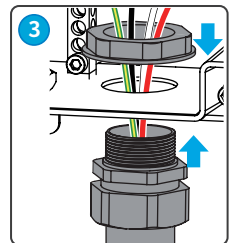
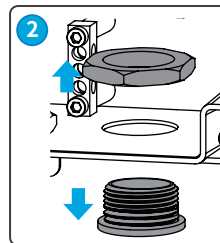
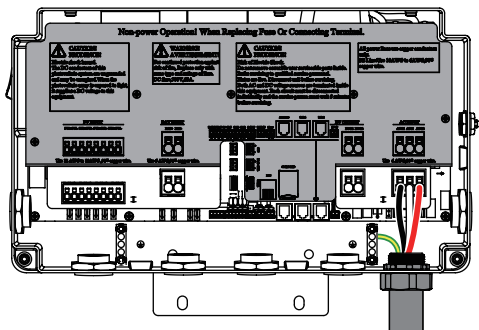

6.7 Connecting the EV cables

DANGER

INSTRUCTIONS PERTAINING TO A RISK OF FIRE OR ELECTRIC SHOCK

- Before installations, read through the EV's user manual to learn about the product and the precautions. Strictly follow its requirements.
- Do not use finger to touch the metal conducting parts of the EV connector.
- Check whether there is damage on the EV charger's appearance. If there is, do not use it.

WARNING

- Connect the battery cables to the corresponding terminals like BAT+, BAT-, and grounding busbar. The inverter may be damaged if the cables are connected to the wrong terminal.
- EV charger communication cable shall be connected to "EV-CP" port. Do not miss the connection.
- Ensure that the whole cable cores are inserted into the terminal holes. No part of the cable core can be exposed.
- Ensure that the cables are connected securely. Otherwise it will cause damage to the inverter due to overheat during its operation.

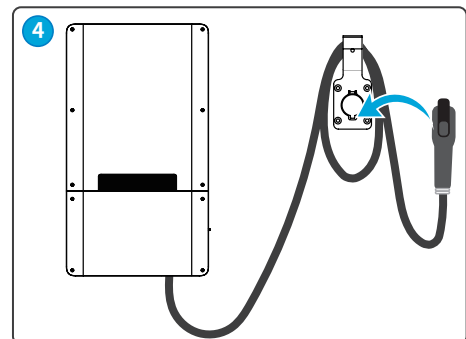
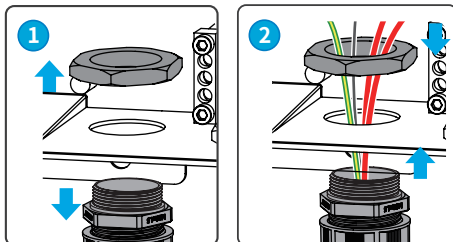
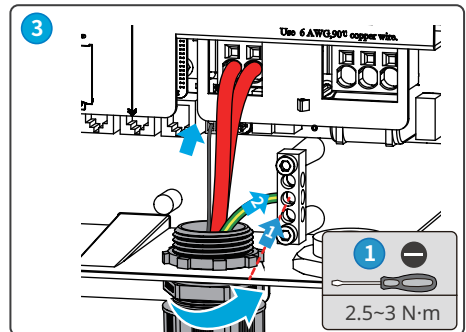
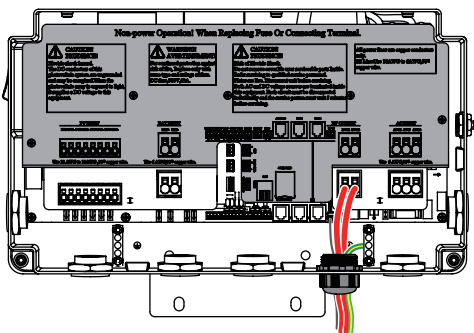

6.8 Communication

NOTICE

Make sure that the communication device is connected to the right COM port. Route the communication cable far away from any interference source or power cable to prevent the signal from being influenced.

6.8.1 Connecting the Communication Cable (Use pin connectors)

The wiring of the battery, meter, EMS, dry contact, E-stop switch I/O communication cables are the same. Below is taking the battery communication cable connection as an example.

NOTICE

When connecting with LG battery, connect the BMS-EN +port on the inverter to ENABLE 12V port on the battery; and connect BMS-EN -port on the inverter to ENABLE GND port on the battery.

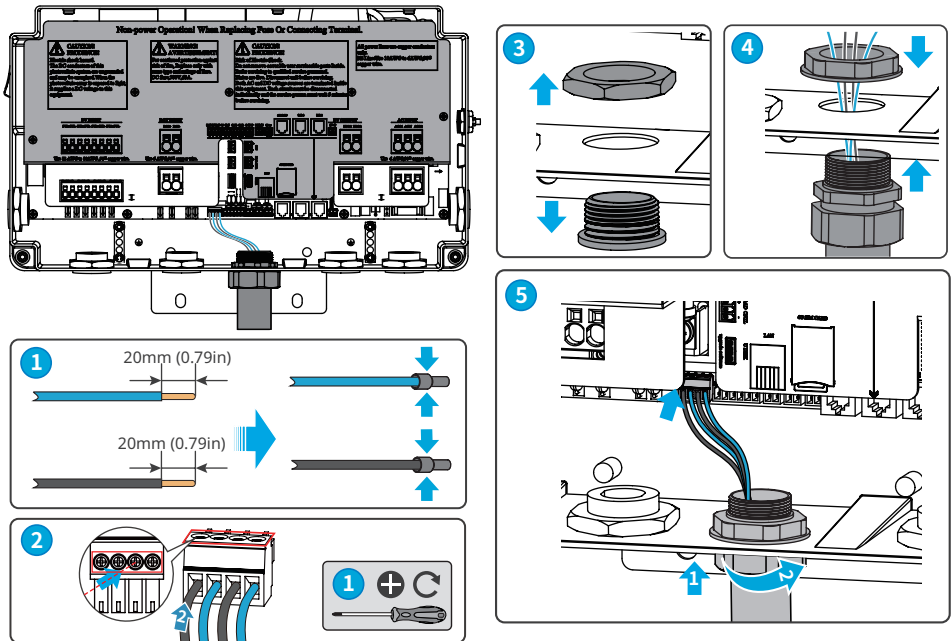

NOTICE

- Connect with the meter for anti reverse current function in the system when there is no ABD box.
- Pay attention to CT connecting direction during the meter cable connection. It will display CT reverse fault on the inverter if it is the opposite direction.
- This sensor is part of a Power Control System. Do not remove. Replace only with same type and rating.
- Ensure the direction on the body part of CT is pointed to the grid.

GMK120 smart meter network

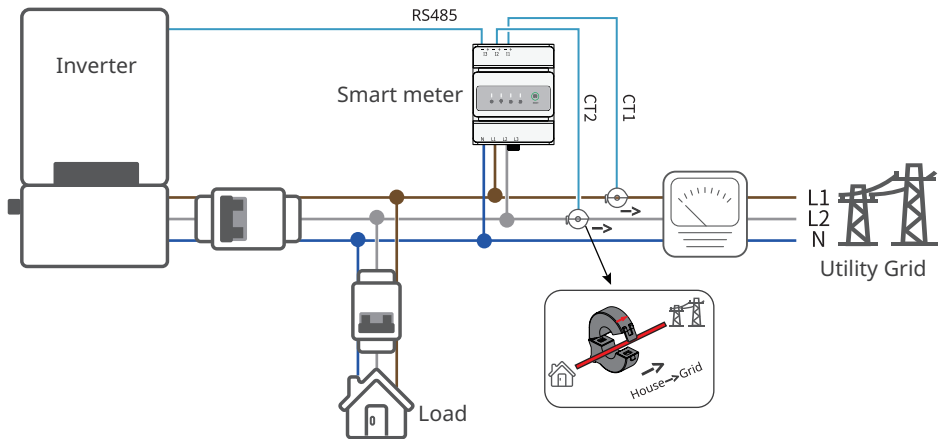

GMK140 smart meter network

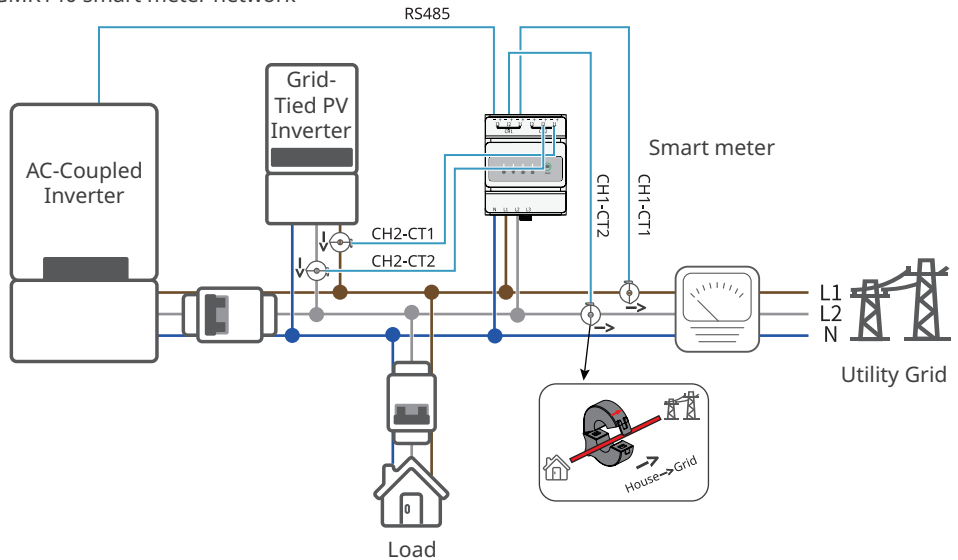

The wiring of the generator and load control communication cables are the same. Below is taking the generator communication cable connection as an example.

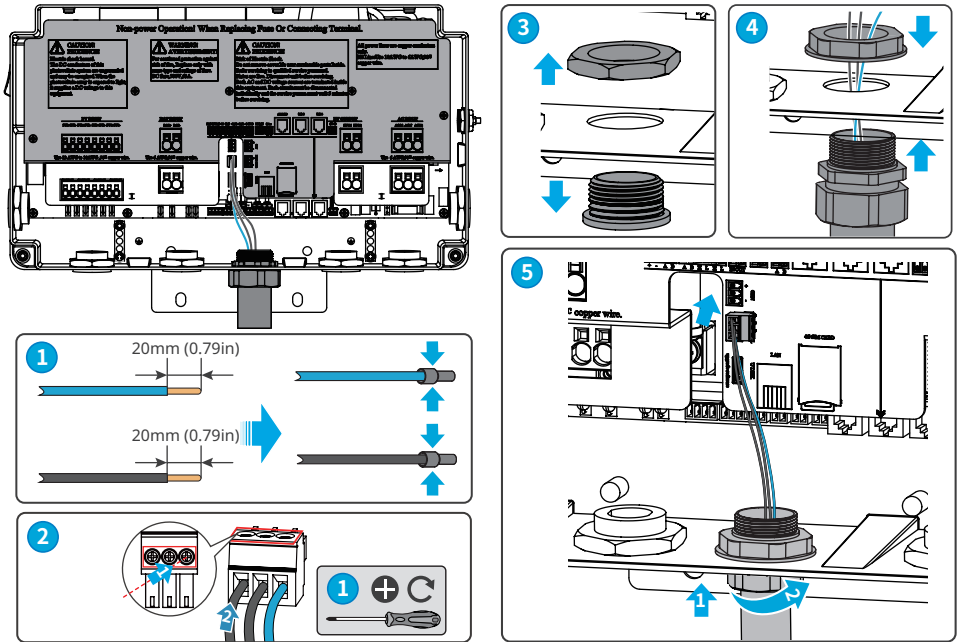

6.8.2 Connecting the Communication Cable (for RJ45 crystal terminal connection)

The wiring of ABD/MPD, LAN and parallel communication cables are the same. Below is taking ABD/MPD communication cable connection as an example.

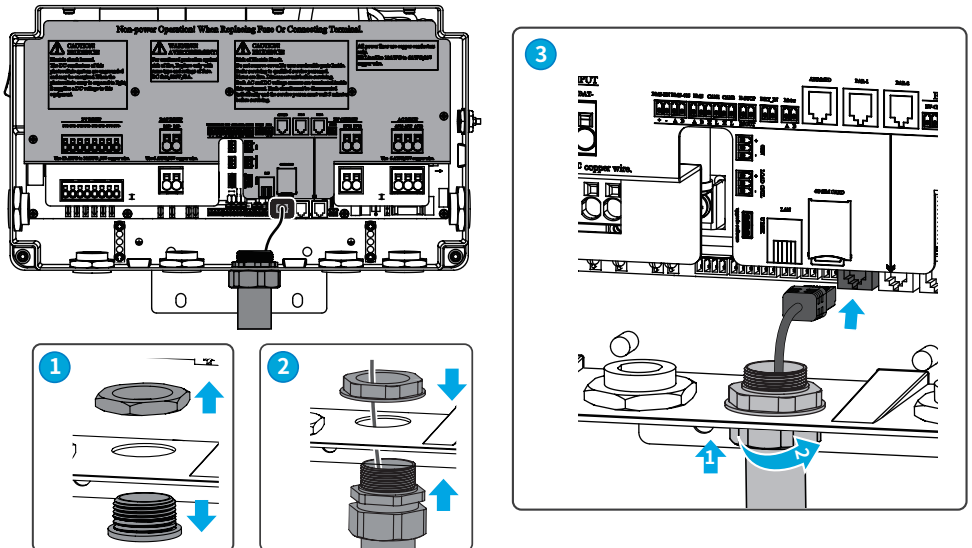

6.8.3 Installing the SIM card (optional)

NOTICE

- SIM cards shall be installed for inverters supporting 4G. The SIM service providers can be obtained by scanning the following QR.
- SIM cards shall be prepared by customers. It is recommended to use SIM cards with standard size(dimension: 25mm×15mm, capacity is ≥64KB) and more than 150M monthly data package .



SIM card service provider

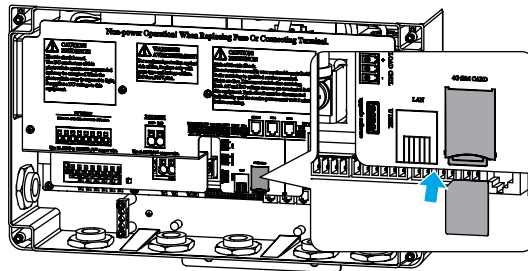

6.8.4 Installing the antenna

NOTICE

The antenna shall be installed when using 4G, WiFi or blue tooth for communication. The ways for their antenna installations are the same. Below is taking 4G antenna installation as an example.

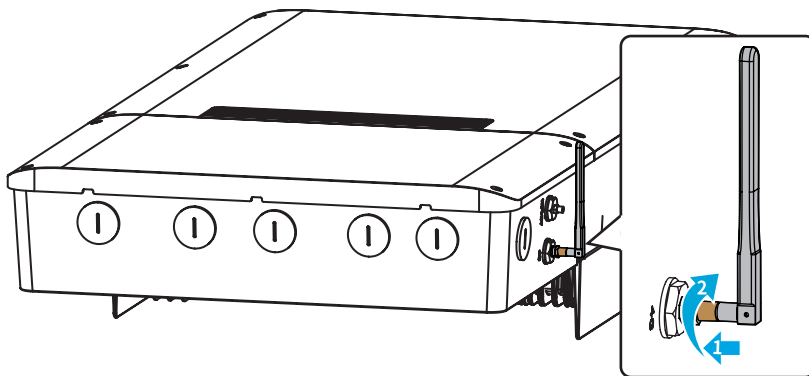

6.8.5 Installing the Cover

NOTICE

- Install the wiring cover after connecting the conductors and wires firmly and correctly.
- Use the hex screws in the accessory bag as spare screws to secure the cover if the cover screws are lost.

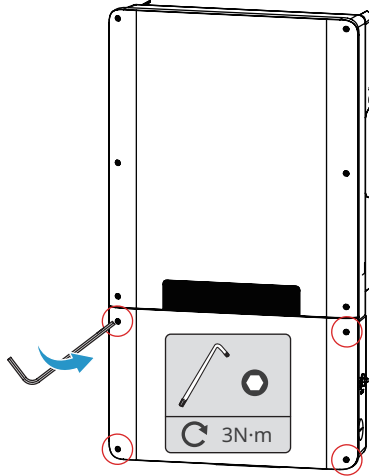

7 Equipment Commissioning

7.1 Check Before Power ON

No.	Check Item
1	The product is firmly installed at a clean place that is well-ventilated and easy-to operate.
2	The PE, DC input, AC output, and communication cables are connected correctly and securely.
3	Cable ties are intact, routed properly and evenly.
4	(Optional) The installation of SIM card is correct and firmly.
5	Unused cable holes are fitted using the waterproof nuts.
6	The electrical conduit holes are sealed.
7	The voltage and frequency at the connection point meet the inverter grid connection requirements.

7.2 Power On

Step 1: Turn on the AC switch between the inverter and the utility grid.

















Step 2: Turn on the DC switch between the inverter and the battery.

Step 3: (optional) Turn on the DC switch between the inverter and the PV string.

Step 4: Turn on the DC switch of the inverter.

8 System Commissioning

8.1 Indicators and Buttons

Indicator	Status	Explanation
		The inverter is power on and in the standby mode.
		The inverter is starting and in the self-check mode.
		The inverter is in normal operation under grid-tied or off-grid modes.
		BACK-UP output overload
		A fault has occurred.
		The inverter is powered off.
		The grid is abnormal and the inverter is in off-grid mode.
		The grid is normal and the inverter is in grid-tied mode.
		BACK-UP is off.
		The monitoring module of the inverter is resetting.
		The inverter fails to connect with Termination.
		Communication fault between Termination and Server.
		The monitoring of the inverter operates well.
		The monitoring module of the inverter has not been started yet.

8.2 Setting Inverter Parameters via SolarGo App

NOTICE

Please set the inverter parameters first via SolarGo App to ensure its operation.

SolarGo App is a smart phone application used to communicate with the inverter via bluetooth, WiFi or 4G modules. Commonly used functions are as follows:

1. Check the operating data, software version, alarms, etc.
2. Set grid parameters, communication parameters, etc.
3. Equipment maintenance.
4. Upgrade software version.

Please refer to the "SolarGo App User Manual" for details, which can be obtained from official website: https://en.goodwe.com/Ftp/EN/Downloads/User%20Manual/GW_SolarGo_User%20Manual-EN.pdf to get the user manual. Or obtained by scanning the following QR code.



SolarGo App



SolarGo App User Manual

8.3 Monitoring via SEMS Portal

SEMS Portal is an monitoring platform used to manage organizations/users, add plants, and monitor plant status.

For more details, refer to the SEMS Portal User Manual. Scan the QR code or visit https://en.goodwe.com/Ftp/EN/Downloads/User%20Manual/GW_SEMS%20Portal-User%20Manual-EN.pdf to get the user manual.



SEMS Portal App



SEMS Portal
User Manual

9 Maintenance

9.1 Power Off the Inverter

**DANGER**

INSTRUCTIONS PERTAINING TO A RISK OF FIRE OR ELECTRIC SHOCK

- Power off the inverter before operations and maintenance. Otherwise, the inverter may be damaged or electric shocks may occur.
- Delayed discharge. Wait until the components are discharged after power off.

Step 1: (optional) Send shutdown command to the inverter.

Step 2: Turn off the AC switch between the inverter and the utility grid.

Step 2: Turn off the DC switch between the inverter and the battery.

Step 3: (optional) Turn off the PV DC switch of the inverter.

Step 4: (optional) Turn off the DC switch between the inverter and the PV string.

9.2 Removing the Inverter

**WARNING**

- Make sure that the inverter is powered off.
- Wear proper PPE before any operations.

Step 1 Disconnect all the cables, including DC cables, AC cables, communication cables, the communication module, and PE cables.

Step 2 Remove the inverter from the mounting plate.

Step 3 Remove the mounting plate.

Step 4 Store the inverter properly. If the inverter needs to be used later, ensure that the storage conditions meet the requirements.

9.3 Disposing of the Inverter

If the inverter cannot work anymore, dispose of it according to the local disposal requirements for electrical equipment waste. The inverter cannot be disposed of together with household waste.

9.4 Troubleshooting

Perform troubleshooting according to the following methods. Contact the after-sales service if these methods do not work.

Collect the information below before contacting the after-sales service, so that the problems can be solved quickly.

1. Inverter information like serial number, software version, installation date, fault time, fault frequency, etc.
2. Installation environment, including weather conditions, whether the PV modules are sheltered or shadowed, etc. It is recommended to provide some photos and videos to assist in analyzing the problem.
3. Utility grid situation.

No.	Fault	Cause	Solutions
1	Utility Loss	<ol style="list-style-type: none"> 1. Utility grid power fails. 2. The AC cable is disconnected, or the AC breaker is off. 	<ol style="list-style-type: none"> 1. The alarm is automatically cleared after the grid power supply is restored. 2. Check whether the AC cable is connected and the AC breaker is on.
2	Grid Overvoltage	The grid voltage exceeds the permissible range, or the duration of high voltage exceeds the requirement of HVRT.	<ol style="list-style-type: none"> 1. If the problem occurs occasionally, the utility grid may be abnormal temporarily. The inverter will recover automatically after detecting that the utility grid is normal. 2. If the problem occurs frequently, check whether the grid voltage is within the permissible range. <ul style="list-style-type: none"> • Contact the local power company if the grid voltage exceeds the permissible range. • Modify the overvoltage protection threshold, HVRT or disable the overvoltage protection function after obtaining the consent of the local power company if the grid frequency is within the permissible range. 3. Check whether the AC breaker and the output cables are connected securely and correctly if the problem persists.

No.	Fault	Cause	Solutions
3	Grid Rapid Overvoltage	The grid voltage is abnormal or ultra-high.	<ol style="list-style-type: none"> 1. If the problem occurs occasionally, the utility grid may be abnormal temporarily. The inverter will recover automatically after detecting that the utility grid is normal. 2. If the problem occurs frequently, check whether the grid voltage is within the permissible range. <ul style="list-style-type: none"> • Contact the local power company if the grid voltage exceeds the permissible range. • Modify the grid overvoltage rapid protection threshold after obtaining the consent of the local power company if the grid voltage is within the permissible range.
4	Grid Undervoltage	The grid voltage is lower than the permissible range, or the duration of low voltage exceeds the requirement of LVRT.	<ol style="list-style-type: none"> 1. If the problem occurs occasionally, the utility grid may be abnormal temporarily. The inverter will recover automatically after detecting that the utility grid is normal. 2. If the problem occurs frequently, check whether the grid voltage is within the permissible range. <ul style="list-style-type: none"> • Contact the local power company if the grid voltage exceeds the permissible range. • Modify the undervoltage protection threshold, LVRT or disable the undervoltage protection function after obtaining the consent of the local power company if the grid frequency is within the permissible range. 3. Check whether the AC breaker and the output cables are connected securely and correctly if the problem persists.

No.	Fault	Cause	Solutions
5	Grid 10min Overvoltage	The moving average of grid voltage in 10min exceeds the range of safety requirements.	<ol style="list-style-type: none"> 1. If the problem occurs occasionally, the utility grid may be abnormal temporarily. The inverter will recover automatically after detecting that the utility grid is normal. 2. If the problem occurs frequently, check whether the grid voltage is within the permissible range. <ul style="list-style-type: none"> • Contact the local power company if the grid voltage exceeds the permissible range. • Modify the grid overvoltage rapid protection threshold after obtaining the consent of the local power company if the grid voltage is within the permissible range.
6	Grid Overfrequency	Utility grid exception. The actual grid frequency exceeds the requirement of the local grid standard.	<ol style="list-style-type: none"> 1. If the problem occurs occasionally, the utility grid may be abnormal temporarily. The inverter will recover automatically after detecting that the utility grid is normal. 2. If the problem occurs frequently, check whether the grid frequency is within the permissible range. <ul style="list-style-type: none"> • Contact the local power company if the grid frequency exceeds the permissible range. • Modify the overfrequency protection threshold or disable the overfrequency protection function after obtaining the consent of the local power company if the grid frequency is within the permissible range.

No.	Fault	Cause	Solutions
7	Grid Underfrequency	Utility grid exception. The actual grid frequency is lower than the requirement of the local grid standard.	<ol style="list-style-type: none"> 1. If the problem occurs occasionally, the utility grid may be abnormal temporarily. The inverter will recover automatically after detecting that the utility grid is normal. 2. If the problem occurs frequently, check whether the grid frequency is within the permissible range. <ul style="list-style-type: none"> • Contact the local power company if the grid frequency exceeds the permissible range. • Modify the underfrequency protection threshold or disable the underfrequency protection function after obtaining the consent of the local power company if the grid frequency is within the permissible range. Or close "Grid Underfrequency" function.
8	Grid Frequency Instability	Utility grid exception. The actual grid frequency change rate does not meet the requirement of the local grid standard.	<ol style="list-style-type: none"> 1. If the problem occurs occasionally, the utility grid may be abnormal temporarily. The inverter will recover automatically after detecting that the utility grid is normal. 2. If the problem occurs frequently, check whether the grid frequency is within the permissible range. <ul style="list-style-type: none"> • Contact the local power company if the grid frequency exceeds the permissible range. • Contact the dealer or the after-sales service if the grid frequency is within the permissible range.

No.	Fault	Cause	Solutions
9	Anti-islanding	The utility grid is disconnected. The utility grid is disconnected according to the safety regulations, but the grid voltage is maintained due to the loads.	<ol style="list-style-type: none"> 1. Check whether the utility grid is disconnected. 2. Contact the dealer or the after-sales service.
10	LVRT Undervoltage	Utility grid exception. The duration of the utility grid exception exceeds the set time of LVRT.	<ol style="list-style-type: none"> 1. If the problem occurs occasionally, the utility grid may be abnormal temporarily. The inverter will recover automatically after detecting that the utility grid is normal. 2. If the problem occurs frequently, check whether the grid frequency is within the permissible range. If not, contact the local power company. If yes, contact the dealer or the after-sales service.
11	HVRT Overvoltage	Utility grid exception. The duration of utility grid exception exceeds the set time of HVRT.	
12	Abnormal GFCI 30mA	The input insulation impedance to the ground decreases when the inverter is working.	<ol style="list-style-type: none"> 1. If the problem occurs occasionally, it may be caused by a cable exception. The inverter will recover automatically after the problem is solved. 2. Check whether the impedance between the PV string and PE is too low if the problem occurs frequently or persists.
13	Abnormal GFCI 60mA		
14	Abnormal GFCI 150mA		
15	Abnormal GFCI		
16	Large DC of AC current L1	The DC component of the output current exceeds the safety range or default range.	<ol style="list-style-type: none"> 1. If the problem is caused by an external fault like a utility grid exception or frequency exception, the inverter will recover automatically after solving the problem. 2. If the problem occurs frequently and the PV station cannot work properly, contact the dealer or the after-sales service.
17	Large DC of AC current L2		

No.	Fault	Cause	Solutions
18	Low Insulation Res.	<ol style="list-style-type: none"> 1. The PV string is short-circuited to PE. 2. The PV system is in a moist environment and the cable is not well insulated to the ground. 	<ol style="list-style-type: none"> 1. Check whether the resistance of the PV string to PE exceeds 50kΩ. If no, check the short circuit point. 2. Check whether the PE cable is connected correctly. 3. If the resistance is lower on rainy days, please reset the ISO.
19	Abnormal Ground	<ol style="list-style-type: none"> 1. The PE cable of the inverter is not connected well. 2. The L cable and N cable are connected reversely when output of the PV string is grounded. 	<ol style="list-style-type: none"> 1. Check whether the PE cable of the inverter is connected properly. 2. Check whether the L cable and N cable are connected reversely if output of the PV string is grounded.
20	Anti Reverse current protection for hardwares	Abnormal fluctuation of load	<ol style="list-style-type: none"> 1. If the exception is caused by an external fault, the inverter will recover automatically after solving the problem. 2. If the problem occurs frequently and the PV station cannot work properly, contact the dealer or the after-sales service.
21	Internal Comm Loss	<ol style="list-style-type: none"> 1. Frame format error 2. Parity checking error 3. Can bus offline 4. Hardware CRC error 5. Send (receive) control bit is receive (send). 6. Transmit to the unit that is not allowed. 	<p>Disconnect the AC output switch and DC input switch, then connect them 5 minutes later. Contact the dealer or the after-sales service if the problem persists.</p>

No.	Fault	Cause	Solutions
22	AC HCT Check abnormal	The sampling of the AC HCT is abnormal.	Disconnect the AC output switch and DC input switch, then connect them 5 minutes later. Contact the dealer or the after-sales service if the problem persists.
23	GFCI HCT Check abnormal	The sampling of the GFCI HCT is abnormal.	Disconnect the AC output switch and DC input switch, then connect them 5 minutes later. Contact the dealer or the after-sales service if the problem persists.
24	Relay Check abnormal	<ol style="list-style-type: none"> 1. The relay is abnormal or short-circuited. 2. The control circuit is abnormal. 3. The AC cable connection is abnormal, like a virtual connection or short circuit. 	Disconnect the AC output switch and DC input switch, then connect them 5 minutes later. Contact the dealer or the after-sales service if the problem persists.
26	Flash Fault	The internal Flash storage is abnormal.	Disconnect the AC output switch and DC input switch, then connect them 5 minutes later. Contact the dealer or the after-sales service if the problem persists.
27	DC Arc Fault	<ol style="list-style-type: none"> 1. The DC terminal is not firmly connected. 2. The DC cable is broken. 	Read the Quick Installation Guide and check whether the cables are connected properly.
28	AFCI Self-check Fault	AFCI detection is abnormal.	Disconnect the AC output switch and DC input switch, then connect them 5 minutes later. Contact the dealer or the after-sales service if the problem persists.

No.	Fault	Cause	Solutions
29	Cavity Overtemperature	<ol style="list-style-type: none"> 1. The inverter is installed in a place with poor ventilation. 2. The ambient temperature exceeds 60°C. 3. A fault occurs in the internal fan of the inverter. 	<ol style="list-style-type: none"> 1. Check the ventilation and the ambient temperature at the installation point. 2. If the ventilation is poor or the ambient temperature is too high, improve the ventilation and heat dissipation. 3. Contact the dealer or after-sales service if both the ventilation and the ambient temperature are normal.
30	BUS Overvoltage	<ol style="list-style-type: none"> 1. The PV voltage is too high. 2. The sampling of the inverter BUS voltage is abnormal. 	Disconnect the AC output switch and DC input switch, then connect them 5 minutes later. Contact the dealer or the after-sales service if the problem persists.
31	PV Input Overvoltage	The PV array configuration is not correct. Too many PV panels are connected in series in the PV string.	Check the serial connection of the PV array. Make sure that the open circuit voltage of the PV string is not higher than the maximum operating voltage of the inverter.
32	PV Continuous Hardware Overcurrent	<ol style="list-style-type: none"> 1. The PV configuration is not proper. 2. The hardware is damaged. 	Disconnect the AC output switch and DC input switch, then connect them 5 minutes later. Contact the dealer or the after-sales service if the problem persists.
33	PV Continuous Software Overcurrent	<ol style="list-style-type: none"> 1. The PV configuration is not proper. 2. The hardware is damaged. 	Disconnect the AC output switch and DC input switch, then connect them 5 minutes later. Contact the dealer or the after-sales service if the problem persists.
34	String1 PV String Reversed	The PV string is connected reversely.	Check whether the PV1 and PV2 strings are connected reversely.
35	String2 PV String Reversed		

9.5 Routine Maintenance

WARNING

- Make sure that the inverter is powered off.
- Wear proper PPE before any operations.

Maintaining Item	Maintaining Method	Maintaining Period
System Clean	Check the heat sink, air intake, and air outlet for foreign matter or dust.	Once 6-12 months
DC Switch	Turn the DC switch on and off ten consecutive times to make sure that it is working properly.	Once a year
Electrical Connection	Check whether the cables are securely connected. Check whether the cables are broken or whether there is any exposed copper core.	Once 6-12 months
Sealing	Check whether all the terminals and ports are properly sealed. Reseal the cable hole if it is not sealed or too big.	Once a year

10 Technical Parameters

10.1 ES Inverter Parameters

Technical Data	GW5000-ES-US20	GW6000-ES-US20	GW7600-ES-US20	GW9600-ES-US20	GW11K4-ES-US20
Battery Input Data					
Battery Type	Li-Ion	Li-Ion	Li-Ion	Li-Ion	Li-Ion
Nominal Battery Voltage (V)	300	300	300	300	300
Battery Voltage Range (V) ^{*1}	80~495	80~495	80~495	80~495	80~495
Max. Continuous Charging Current (A)	50	50	50	50	50
Max. Continuous Discharging Current (A)	50	50	50	50	50
Max. Charge Power (W)	5,000	6,000	7,600	9,600	11,400
Max. Discharge Power (W)	5,250	6,300	7,980	10,080	11,970
PV String Input Data					
Max. Input Power (W)	7,500	9,000	11,400	14,400	17,100
Max. Input Voltage (V) ^{*2}	600	600	600	600	600
MPPT Operating Voltage Range (V) ^{*3}	50~550	50~550	50~550	50~550	50~550
MPPT Voltage Range at Nominal Power (V)	235~500	285~500	180~500	225~500	270~500
Start-up Voltage (V)	60	60	60	60	60
Nominal Input Voltage (V)	390	390	390	390	390
Max. Input Current per MPPT (A)	16	16	16	16	16
Max. Short Circuit Current per MPPT (A)	23.4	23.4	23.4	23.4	23.4
Max. Backfeed Current to The Array (A)	0	0	0	0	0
Number of MPP Trackers	2	2	4	4	4
Number of Strings per MPPT	1	1	1	1	1
AC Output Data (On-grid)					
Nominal Apparent Power Output to Utility Grid (VA)	5,000	6,000	7,600	9,600	11,400
Max. Apparent Power Output to Utility Grid (VA)	5,000	6,000	7,600	9,600	11,400

Technical Data	GW5000-ES-US20	GW6000-ES-US20	GW7600-ES-US20	GW9600-ES-US20	GW11K4-ES-US20
Nominal Apparent Power from Utility Grid (VA)	5,000	6,000	7,600	9,600	11,400
Max. Apparent Power from Utility Grid (VA)	5,000	6,000	7,600	9,600	11,400
Max. Apparent Power from Utility Grid Without EV Charger (VA)	5,000	6,000	7,600	9,600	11,400
Nominal Apparent Power from Utility Grid With EV Charger (VA)	9,600	9,600	9,600	9,600	11,400
Nominal Output Voltage (V)	240	240	240	240	240
Output Voltage Range (V)	211~264	211~264	211~264	211~264	211~264
Nominal AC Grid Frequency (Hz)	60	60	60	60	60
AC Grid Frequency Range (Hz)	58.5~61.2	58.5~61.2	58.5~61.2	58.5~61.2	58.5~61.2
Max. AC Current Output to Utility Grid (A)	20.8	25.0	31.7	40.0	47.5
Max. AC Current From Utility Grid (A)	20.8	25.0	31.7	40.0	47.5
Max. AC Current From Utility Grid Without EV Charger (A)	20.8	25.0	31.7	40.0	47.5
Max. AC Current From Utility Grid With EV Charger (A)	40.0	40.0	40.0	40.0	47.5
Nominal AC Current From Utility Grid (A)	20.8	25.0	31.7	40.0	47.5
Max. Output Fault Current (Peak and Duration) (A)	392A @ 219ms	392A @ 219ms	392A @ 219ms	392A @ 219ms	392A @ 219ms
Inrush Current (Peak and Duration) (A)	10A@10ms	10A@10ms	10A@10ms	10A@10ms	10A@10ms
Nominal Output Current (A)	20.8	25.0	31.7	40.0	47.5
Power Factor	~1 (Adjustable from 0.8 leading to 0.8 lagging)				
Max. Total Harmonic Distortion	<3%	<3%	<3%	<3%	<3%

Technical Data	GW5000-ES-US20	GW6000-ES-US20	GW7600-ES-US20	GW9600-ES-US20	GW11K4-ES-US20
Maximum Output Overcurrent Protection Without EV Charger (A)	30	35	40	50	60
Maximum Output Overcurrent Protection With EV Charger (A)	50	50	50	50	60
Type of Voltage (a.c. or d.c.)	a.c.	a.c.	a.c.	a.c.	a.c.
AC Output Data (Back-up)					
Back-up Nominal Apparent Power (VA)	5,000	6,000	7,600	9,600	11,400
Max. Output Apparent Power (VA)*4	5,000 (6,000 @ 60sec)	6000 (7,200 @ 60sec)	7,600 (9,120 @ 60sec)	9,600 (11,520 @ 60sec)	11,400 (13,680 @ 60sec)
Nominal Output Current (A)	20.8	25.0	31.7	40.0	47.5
Max. Output Current (A)	20.8	25.0	31.7	40.0	47.5
Max. Output Fault Current (Peak and Duration) (A)	392A @ 219ms	392A @ 219ms	392A @ 219ms	392A @ 219ms	392A @ 219ms
Inrush Current (Peak and Duration) (A)	10A @ 10ms	10A @ 10ms	10A @ 10ms	10A @ 10ms	10A @ 10ms
Maximum Output Overcurrent Protection Without EV Charger (A)	30	35	40	50	60
Maximum Output Overcurrent Protection With EV Charger (A)	50	50	50	50	60
Nominal Output Voltage (V)	240/120	240/120	240/120	240/120	240/120
Nominal Output Frequency (Hz)	60	60	60	60	60
Output THDv (@Linear Load)	<3%	<3%	<3%	<3%	<3%
Efficiency					
Max. Efficiency	97.6%				
CEC Efficiency	97.0%				

Technical Data	GW5000-ES-US20	GW6000-ES-US20	GW7600-ES-US20	GW9600-ES-US20	GW11K4-ES-US20
Max. Battery to AC Efficiency	97.0%				
MPPT Efficiency	99.9%				
Protection					
PV String Current Monitoring	Integrated				
PV Insulation Resistance Detection	Integrated				
Residual Current Monitoring	Integrated				
PV Reverse Polarity Protection	Integrated				
Battery Reverse Polarity Protection	Integrated				
Anti-islanding Protection	Integrated				
AC Overcurrent Protection	Integrated				
AC Short Circuit Protection	Integrated				
AC Overvoltage Protection	Integrated				
DC Switch	Integrated				
DC Surge Protection	Type II	Type II	Type II	Type II	Type II
AC Surge Protection	Type III	Type III	Type III	Type III	Type III
AFCI	Integrated				
Battery Arc Fault Detection	Integrated				
Emergency Power Off	Integrated				
Rapid Shutdown	Integrated				
Rapid Shutdown	Integrated				
General Data					
Operating Temperature Range (°F)	-31°F~+140°F (-35°C~+60°C)				
Relative Humidity	0~95%				

Technical Data	GW5000-ES-US20	GW6000-ES-US20	GW7600-ES-US20	GW9600-ES-US20	GW11K4-ES-US20
Max. Operating Altitude (ft)	9842ft (3000m)				
Cooling Method	Natural Convection				
User Interface	LED, APP	LED, APP	LED, APP	LED, APP	LED, APP
Communication with BMS	RS485, CAN	RS485, CAN	RS485, CAN	RS485, CAN	RS485, CAN
Communication with Meter	RS485	RS485	RS485	RS485	RS485
Communication with Portal	Bluetooth, WiFi, LAN, 4G (Optional)				
Weight (lb)	72.3	72.3	76.7	84.9	84.9
Dimension (W×H×D in)	19.1×35.4×7.5 in (485×900×191.5 mm)				
Noise Emission (dB)	<20	<20	<40	<40	<40
Topology	Non-isolated				
Self-consumption at Night (W)*5	<20				
Ingress Protection Rating	NEMA Type 4X				
DC Connector	Push-in Spring Connection				
AC Connector	Push-in Spring Connection				
Environmental Category	4K4H				
Pollution Degree	III				
Overvoltage Category	DC II / AC IV				
Protective Class	I				
Storage Temperature (°F)	-40°F~+185°F (-40°C~+85°C)				
The Decisive Voltage Class (DVC)	Battery: C PV: C AC: C Com: C				
Mounting Method	Wall Mounted				
Active Anti-islanding Method	AFDPF + AQDPF *6				

Technical Data	GW5000-ES-US20	GW6000-ES-US20	GW7600-ES-US20	GW9600-ES-US20	GW11K4-ES-US20
Type of Electrical Supply System	Split phase				
Country of Manufacture	China				
General Data					
Grid Standards	UL1741 SB, California Rule 21, HECO Rule 14, IEEE 1547, IEEE 1547.1				
Safety Regulation	UL 1741, CSA 22.2 No. 107.1, UL 1998, UL1699B				
EMC	FCC part15 CLASS B				
<p>*1: Battery discharge/charge power limited by voltage</p> <p>*2: Inverter will not work when PV input voltage $\geq 585V$.</p> <p>*3: When there is no battery connected, inverter starts feeding in only if string voltage is higher than 200V.</p> <p>*4: Can be reached only if PV and battery power is enough</p> <p>*5: No Back-up Output</p> <p>*6: AFDPF: Active Frequency Drift with Positive Feedback, AQDPF: Active Q Drift with Positive Feedback.</p>					

10.2 SBP Inverter Parameters

Technical Data	GW5000-SBP-US20	GW6000-SBP-US20	GW7600-SBP-US20	GW9600-SBP-US20	GW11K4-SBP-US20
Battery Input Data					
Battery Type	Li-Ion	Li-Ion	Li-Ion	Li-Ion	Li-Ion
Nominal Battery Voltage (V)	300	300	300	300	300
Battery Voltage Range (V)*1	80~495	80~495	80~495	80~495	80~495
Max. Continuous Charging Current (A)	50	50	50	50	50
Max. Continuous Discharging Current (A)	50	50	50	50	50
Max. Charge Power (W)	5,000	6,000	7,600	9,600	11,400
Max. Discharge Power (W)	5,250	6,300	7,980	10,080	11,970
AC Output Data (On-grid)					
Nominal Apparent Power Output to Utility Grid (VA)	5,000	6,000	7,600	9,600	11,400
Max. Apparent Power Output to Utility Grid (VA)	5,000	6,000	7,600	9,600	11,400
Nominal Apparent Power from Utility Grid (VA)	5,000	6,000	7,600	9,600	11,400
Max. Apparent Power from Utility Grid (VA)	5,000	6,000	7,600	9,600	11,400
Max. Apparent Power from Utility Grid Without EV Charger (VA)	5,000	6,000	7,600	9,600	11,400
Nominal Apparent Power from Utility Grid With EV Charger (VA)	9,600	9,600	9,600	9,600	11,400
Nominal Output Voltage (V)	240	240	240	240	240
Output Voltage Range (V)	211~264	211~264	211~264	211~264	211~264
Nominal AC Grid Frequency (Hz)	60	60	60	60	60
AC Grid Frequency Range (Hz)	58.5~61.2	58.5~61.2	58.5~61.2	58.5~61.2	58.5~61.2
Max. AC Current Output to Utility Grid (A)	20.8	25.0	31.7	40.0	47.5
Max. AC Current From Utility Grid (A)	20.8	25.0	31.7	40.0	47.5

Technical Data	GW5000-SBP-US20	GW6000-SBP-US20	GW7600-SBP-US20	GW9600-SBP-US20	GW11K4-SBP-US20
Max. AC Current From Utility Grid Without EV Charger (A)	20.8	25.0	31.7	40.0	47.5
Max. AC Current From Utility Grid With EV Charger (A)	40.0	40.0	40.0	40.0	47.5
Nominal AC Current From Utility Grid (A)	20.8	25.0	31.7	40.0	47.5
Max. Output Fault Current (Peak and Duration) (A)	392A @ 219ms	392A @ 219ms	392A @ 219ms	392A @ 219ms	392A @ 219ms
Inrush Current (Peak and Duration) (A)	10A@10ms	10A@10ms	10A@10ms	10A@10ms	10A@10ms
Nominal Output Current (A)	20.8	25.0	31.7	40.0	47.5
Power Factor	~1 (Adjustable from 0.8 leading to 0.8 lagging)				
Max. Total Harmonic Distortion	<3%	<3%	<3%	<3%	<3%
Maximum Output Overcurrent Protection Without EV Charger (A)	30	35	40	50	60
Maximum Output Overcurrent Protection With EV Charger (A)	50	50	50	50	60
Type of Voltage (a.c. or d.c.)	a.c.	a.c.	a.c.	a.c.	a.c.
AC Output Data (Back-up)					
Back-up Nominal Apparent Power (VA)	5,000	6,000	7,600	9,600	11,400
Max. Output Apparent Power (VA)*2	5,000 (6,000 @ 60sec)	6,000 (7,200 @ 60sec)	7,600 (9,120 @ 60sec)	9,600 (11,520 @ 60sec)	11,400 (13,680 @ 60sec)
Nominal Output Current (A)	20.8	25.0	31.7	40.0	47.5
Max. Output Current (A)	20.8	25.0	31.7	40.0	47.5
Max. Output Fault Current (Peak and Duration) (A)	392A @ 219ms	392A @ 219ms	392A @ 219ms	392A @ 219ms	392A @ 219ms
Inrush Current (Peak and Duration) (A)	10A @ 10ms	10A @ 10ms	10A @ 10ms	10A @ 10ms	10A @ 10ms

Technical Data	GW5000-SBP-US20	GW6000-SBP-US20	GW7600-SBP-US20	GW9600-SBP-US20	GW11K4-SBP-US20
Maximum Output Overcurrent Protection Without EV Charger (A)	30	35	40	50	60
Maximum Output Overcurrent Protection With EV Charger (A)	50	50	50	50	60
Nominal Output Voltage (V)	240/120	240/120	240/120	240/120	240/120
Nominal Output Frequency (Hz)	60	60	60	60	60
Output THDv (@Linear Load)	<3%	<3%	<3%	<3%	<3%
Efficiency					
Max. Efficiency	97.0%				
CEC Efficiency	96.0%				
Max. Battery to AC Efficiency	97.0%				
Protection					
Residual Current Monitoring	Integrated				
Battery Reverse Polarity Protection	Integrated				
Anti-islanding Protection	Integrated				
AC Overcurrent Protection	Integrated				
AC Short Circuit Protection	Integrated				
AC Overvoltage Protection	Integrated				
AC Surge Protection	Type III				
Battery Arc Fault Detection	Integrated				
Emergency Power Off	Integrated				
General Data					
Operating Temperature Range (°F)	-31°F~+140°F (-35°C~+60°C)				
Relative Humidity	0~95%				

Technical Data	GW5000-SBP-US20	GW6000-SBP-US20	GW7600-SBP-US20	GW9600-SBP-US20	GW11K4-SBP-US20
Max. Operating Altitude (ft)	9842ft (3000m)				
Cooling Method	Natural Convection				
User Interface	LED, APP	LED, APP	LED, APP	LED, APP	LED, APP
Communication with BMS	RS485, CAN	RS485, CAN	RS485, CAN	RS485, CAN	RS485, CAN
Communication with Meter	RS485	RS485	RS485	RS485	RS485
Communication with Portal	Bluetooth, WiFi, LAN, 4G (Optional)				
Weight (lb)	72.3	72.3	76.7	84.9	84.9
Dimension (W×H×D in)	19.1×35.4×7.5 in (485×900×191.5 mm)				
Noise Emission (dB)	<20	<20	<40	<40	<40
Topology	Non-isolated				
Self-consumption at Night (W)* ³	<20				
Ingress Protection Rating	NEMA Type 4X				
DC Connector	Push-in Spring Connection				
AC Connector	Push-in Spring Connection				
Environmental Category	4K4H				
Pollution Degree	III				
Overtoltage Category	DC II / AC IV				
Protective Class	I				
Storage Temperature (°F)	-40°F~+185°F (-40°C~+85°C)				
The Decisive Voltage Class (DVC)	Battery: C PV: C AC: C Com: C				
Mounting Method	Wall Mounted				
Active Anti-islanding Method	AFDPF + AQDPF * ⁴				

Technical Data	GW5000-SBP-US20	GW6000-SBP-US20	GW7600-SBP-US20	GW9600-SBP-US20	GW11K4-SBP-US20
Type of Electrical Supply System	Split phase				
Country of Manufacture	China				
General Data					
Grid Standards	UL1741 SB, California Rule 21, HECO Rule 14, IEEE 1547, IEEE 1547.1				
Safety Regulation	UL 1741, CSA 22.2 No. 107.1, UL 1998, UL1699B				
EMC	FCC part15 CLASS B				
<p>*1: Battery discharge/charge power limited by voltage. The maximum battery voltage is 450V for AC-Coupled inverters in the microgrid application.</p> <p>*2: Can be reached only if PV and battery power is enough.</p> <p>*3: No Back-up Output.</p> <p>*4: AFDPF: Active Frequency Drift with Positive Feedback, AQDPF: Active Q Drift with Positive Feedback.</p>					

10.3 Technical Parameters for EV Charger

Technical Data	EV Charger
AC Output Data	
Charging Level	AC Level 2
Nominal AC Power Output (W)	9600
Nominal AC Frequency(Hz)	60
Maximum Continuous Output Current (A)	40* ¹
EV Charger Configuration & Indicator	APP (WiFi, Bluetooth)
EV Charger Cable Length* ²	7.6m
EV Charger Cable Operating Temperature Range	-31°F~140°F (-35°C~60°C)
Operating Altitude	≤ 9842ft (3000m)
Protection Degree	NEMA Type 4X
Certifications & Standards	
Safety Regulation	UL2594, UL2231-1, UL2231-2, NEC Article 625 compliant
EV Charger	SAE J1772
*1: The maximum is 40A, you can choose 32A, 24A or 16A, the factory default is 16A..	
*2: EV charger cable ordered separately.	

11 Appendix

11.1 Inverter Parameter Precision

For parameter, which used in grid support and protection function, adjustable requirement of CA Rule 21, HECO 14H and IEEE1547, the relevant explanations and setting methods can obtain by reading, <Parameter Adjustable Method Of Grid Support Utility Interactive Inverter>, the document can be obtained by contacting the after-sales.

Time frame	Steady-state measurements			Transient measurements		
	Minimum measurement accuracy	Measurement window	Range	Minimum measurement accuracy	Measurement window	Range
Voltage, RMS	($\pm 1\% V_{nom}$)	10 cycles	0.5 p.u. to 1.2 p.u.	($\pm 2\% V_{nom}$)	5 cycles	0.5 p.u. to 1.2 p.u.
Frequency ^b	10 mHz	60 cycles	50 Hz to 66 Hz	100 mHz	5 cycles	50 Hz to 66 Hz
Active Power	($\pm 5\% S_{rated}$)	10 cycles	0.2 p.u. < P < 1.0 p.u.	Not required	N/A	N/A
Reactive Power	($\pm 5\% S_{rated}$)	10 cycles	0.2 p.u. < Q < 1.0 p.u.	Not required	N/A	N/A
Time	1% of measured duration	N/A	5s to 600s	2 cycles	N/A	100 ms < 5 s



Official Website

GoodWe Technologies Co.,Ltd.

 No. 90 Zijin Rd., New District, Suzhou, 215011, China

 www.goodwe.com

 service@goodwe.com



Contact Information